

INSTRUCTION

MANUAL

FT-901DM

YAESU MUSEN CO., LTD.

TOKYO JAPAN

TABLE CONTENTS

	(Page)
GENERAL	1
SPECIFICATIONS	2
CONTROLS AND SWITCHES	5
REAR APRON CONNECTIONS.....	8
INSTALLATION	11
OPERATION	16
BLOCK DIAGRAM.....	19
CIRCUIT DESCRIPTION.....	20
MAINTENANCE AND ALIGNMENT.....	41

ALL MODE HF TRANSCEIVER FT-901DM



GENERAL DESCRIPTION

The FT-901DM is a precision engineered, high-performance HF transceiver of advanced design, providing all band coverage (160 - 10 meters) on all modes of operation: LSB, USB, CW, FSK, AM, and FM. This transceiver operates at an input power of 180 watts SSB/CW and 80 watts on AM, FM, and FSK.

Advanced features include PLL (Phase Locked Loop) frequency derivation, digital plus analog frequency readout with large display LED digits, a built-in Curtis 8043 IC electronic keyer, and memory frequency control circuitry. State-of-the-art receiver performance features include rejection tuning, dual-filter variable IF bandwidth tuning, and, for CW, an audio peak filter (APF) for unsurpassed rejection of unwanted signals. Other built-in features include VOX, semi-break-in CW with sidetone, 25 kHz calibrator, advanced noise blanker, RF speech processor, and a 20 dB RF attenuator for protection against receiver overload.

All circuits, except the transmitter driver and final amplifier stages, are solid state, utilizing modern plug-in printed circuit boards, thus permitting easy maintenance.

The FT-901DM transceiver is entirely self-contained, requiring only an antenna and power source for operation. For base station operation, AC power voltages of 100/110/117/200/220/234 VAC may be chosen, though the unit normally is supplied with 117 volt capability. A DC-DC converter unit provides for mobile or portable operation. Selection of AC or DC power source is automatically made when the proper line cord is inserted.

For mobile operation a separate switch is provided on the front panel to turn off the tube heaters while in the receive mode. With the heaters off, current consumption is only 1.1 amp.

Among the available options on economy models FT901D/SD/DE are the memory unit, the keyer unit, the DC-DC converter, the FM unit, and the cooling fan. Optional equipment on all models are the 600 Hz CW filter and the 6 kHz AM filter.

The entire FT-901DM transceiver weighs approximately 18 kg., and is 342 mm wide, 154 mm high, and 324 mm deep. A diecast front panel and heavy-duty case provide maximum protection against damage from shock and vibration during travel use.

SPECIFICATIONS

GENERAL

Frequency coverage:

160m	1.8 - 2.0 MHz
80m	3.5 - 4.0 MHz
40m	7.0 - 7.5 MHz
20m	14.0 - 14.5 MHz
15m	21.0 - 21.5 MHz
10mA	28.0 - 28.5 MHz
10mB	28.5 - 29.0 MHz
10mC	29.0 - 29.5 MHz
10mD	29.5 - 29.9 MHz
WWV/JJY	15.0 - 15.5 MHz, RX only

Power requirements:

AC	100/110/117/200/220/234 V, 50/60 Hz
DC	13.5 V, negative ground
(DC option FT-901D/SD/DE)	

Power consumption:

(FT-901DM/D/DE)	
AC 117 V:	70 watts receive (45 watts HEATER OFF) 320 watts transmit (max)
DC 13.5 V:	5A receive (1.1 A HEATER OFF) 21 A transmit (max)
(FT-901S)	
AC 117V:	55 watts receive (45 watts HEATER OFF) 105 watts transmit (max)
DC 13.5 V:	3.8 A receive (0.8 A HEATER OFF) 7.5 A transmit (max)

Size:

342 (W) x 154 (H) x 324 (D) mm

Weight:

18 kg

TRANSMITTER

Emission:

LSB, USB (A3j), CW (A1), AM (A3h), FM (F3) (option FT-901SD/DE), FSK (F1)

PA input power:

FT-901DM/D/DE	
SSB/CW:	180 watts DC
AM/FSK/FM:	80 watts DC
FT-901SD	
SSB/CW/FSK/FM:	20 watts DC
AM:	5 watts DC

Carrier suppression:

Better than 40 dB

Unwanted sideband suppression:

Better than 40 dB @ 1000 Hz

Spurious radiation:

Better than 40 dB below rated output

Transmitter frequency response:

300 - 2700 Hz (-6 dB)

Third order distortion products:

Better than 31 dB below rated output

Transmitter frequency stability:

Less than 300 Hz after 10 minute warmup;
less than 100 Hz after 30 minute warmup.

Negative feedback:

6 dB at 14 MHz

Modulation:

A3J: Balanced modulator
A3h: Amplitude modulation of a low power stage
F3: Variable-reactance frequency modulation, max. deviation ± 5 kHz (F3 feature optional on FT-901SD/DE)

Antenna output impedance:

50 - 75 Ohms, unbalanced

Microphone input impedance:

500 - 600 Ohms

RECEIVER

Sensitivity:

SSB/CW/FSK	0.25 μ V for S/N 10 dB
AM	1 μ V for S/N 10 dB
FM	0.3 μ V for 20 dB quieting

Image rejection:

1.8 - 21 MHz	-- Better than 60 dB
28 MHz	-- Better than 50 dB

IF rejection :

Better than 70 dB

Selectivity, WIDTH control at "0"

SSB:	-6 dB/2.4 kHz	-60 dB/4.0 kHz
*CW:	-6 dB/0.6 kHz	-60 dB/1.2 kHz
*AM:	-6 dB/6.0 kHz	-60 dB/12.0 kHz
**FM:	-6 dB/12.0 kHz	-60 dB/24.0 kHz
*AM and CW filters are optional, all models		
**FM UNIT optional on FT-901SD/DE		

Passband tuning:

Continuous from 2.4 kHz to 300 Hz

Intermodulation:

Better than 80 dB immunity at 20 kHz offset
20 dB inputs at 14 MHz

Desensitization:

Better than 100 dB immunity at 20 kHz off
20 dB input at 14 MHz

APF response:

Within 3 dB from 400 - 900 Hz

Audio output:

Better than 3 watts @ 10% THD

Audio output impedance:

4 - 16 Ohms

FT-901D/SD/DE/DM MODEL DIFFERENCES

○ = Built-in feature

× = Available option

FEATURE	FT-901D	FT-901SD	FT-901DE	FT-901DM
BAND CRYSTAL 160m	○	○	○	○
BAND CRYSTAL 80m	○	○	○	○
BAND CRYSTAL 40m	○	○	○	○
BAND CRYSTAL 15m	○	○	○	○
BAND CRYSTAL 10mA	○	○	○	○
BAND CRYSTAL 10mB	○	○	○	○
BAND CRYSTAL 10mC	○	○	○	○
BAND CRYSTAL 10mD	○	○	○	○
BAND CRYSTAL WWV/JJY RCV	○	○	○	○
VOX/MARKER UNIT	○	○	○	○
FM UNIT	○	×	×	○
RF SPEECH PROCESSOR	○	○	○	○
AM FILTER	×	×	×	×
CW FILTER	×	×	×	×
KEYER UNIT	×	×	○	○
MEMORY UNIT	×	×	×	○
DC-DC CONVERTER	×	×	×	○
COOLING FAN	○	×	○	○
POWER OUTPUT	100 W	10 W	100 W	100 W

TUBE COMPLEMENT		FET:		MSM5501	1	Varactor diodes:	
		2SK19GR	15	MSM5562	1	1S2209	2
12BY7A	1	2SK19BL	8	MSM5564	1	1S2236	1
6146B	2	2SK34E	1	SN75450B	1	FC63	1
		3SK40M	14	SN76514N	1	MV104	10
SEMICONDUCTOR COMPLEMENT		3SK59Y	1	SN74LS00N	2	Silicon varistor diodes:	
		3SK59GR	1	SN74L04N	3	MV13	1
		JF1033B	5	SN74LS90N	1	Zener diodes:	
Germanium transistors:				SN74LS123N	1	WZ050	2
T20A6	2	IC:		SN74LS192N	5	WZ090	4
		8043	1	TA7060P	1	WZ110	2
Silicon transistors:		μ PC78L05	2	TA7061AP	2	Light-emitting diodes:	
2SA564A	2	μ PC78L08	5	TA7063P	2	GD4-203SRD	11
2SA639	1	μ PC14305	2	TA7089M	1	Light-emitting display:	
2SA733	4	μ PC14308	2	TA7205AP	1	HP5082-7740	6
2SC372Y	3	μ PC14312	1	TA7310P	1		
2SC373	10	F4024CP	1	TC5032P	1		
2SC535A	1	F40192	2	Germanium diodes:			
2SC735Y	3	LM308	1	IN60	17		
2SC7850	5	MC1416P	1	1S188FM	6		
2SC945	3	MC3403P	1	1S1007 (GB)	22		
2SC1000GR	5	MC4044P	2	(1N270)			
2SC1815GR	2	(μ PC1008C)		Silicon diodes:			
2SC1815Y	49	MC14011B	3	1S1555	89		
2N4427	1	MC14042B	5	10D1	7		
MPSA13	1	MM74C90	1	10D10	8		
		MSL980Y3	1	VO6B	2		
		MSL980Y4	1				
		MSM561	3				

Specifications subject to change without notice.

CONTROLS AND SWITCHES

This transceiver has been specifically designed for ease of operation and versatility. The operator may, however, be unfamiliar with the operation of the controls, and improper adjustment thereof may result in poor transceiver performance. Thus,

be certain that you understand the function of every control before operating the transceiver. The various front panel controls and switches are described in the following section.

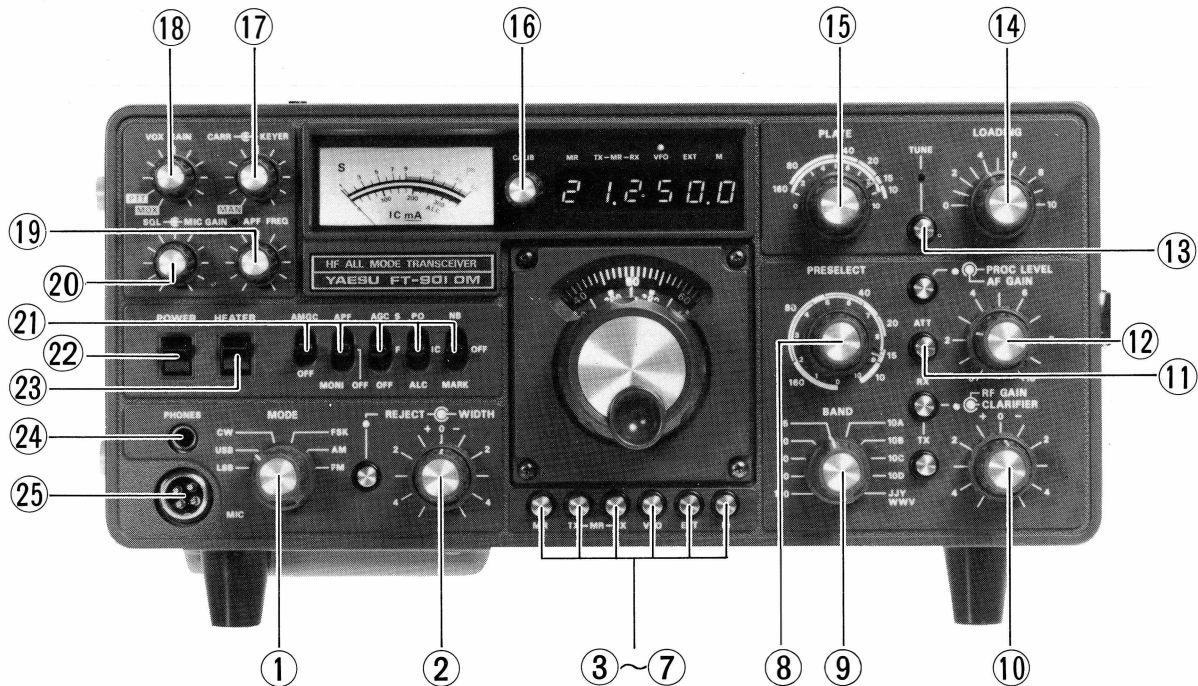

(1) MODE

The MODE switch has six positions for selection of the operating mode desired: LSB, USB, CW, FSK, AM, or FM.

(2) REJECT-WIDTH

The REJECT and WIDTH controls are mounted on concentric shafts. The rejection tuning control (REJECT), when activated by pressing the small silver pushbutton to the left of the REJECT knob, provides a variable IF notch filter action for nulling out a particular interfering signal.

The WIDTH control varies the signal across the passband of one of the two IF 8-pole crystal band-pass filters used in this circuit, thus providing a variable IF bandwidth for rejection of signals above or below the desired signal.

(3) M

The M button is pressed to store a frequency in the memory circuitry. Whatever frequency is being read out on the digital display will be the frequency stored when the M button is pushed.

(4) EXT

When pushed, the EXT button transfers frequency control from the FT-901DM to an external VFO, such as the FV-901 fully synthesized scanning VFO.

(5) VFO

When the VFO button is pushed, frequency control is transferred from EXT or memory control to the FT-901DM internal VFO.

(6) TX-MR-RX

Once a frequency has been stored by the memory (M) button, that frequency may be recalled for control of either the transmit or receive frequency by pushing either the TX or RX MR button, respectively.

(7) MR

Once a frequency has been stored by the memory (M) button, that frequency may be recalled for control of the transceiver frequency by pushing the MR button.

(8) PRESELECT

This control pretunes the signal circuits for both transmit and receive. The PRESELECT circuit provides continuous permeability tuning throughout the frequency range of the transceiver.

(9) BAND

The BAND switch provides selection of the band desired, 160 through 10 meters plus WWV/JJY (receive only).

(10) RF GAIN/CLARIFIER

The RF GAIN and CLARIFIER controls are mounted on concentric shafts. The RF GAIN control provides manual control of the gain levels of the RF and IF amplifiers on receive.

The CLARIFIER control allows manual offset of ± 2.5 kHz of either the transmit or receive frequency. Selection of transmit or receive clarifier is made by the two silver pushbuttons to the left of the CLARIFIER control.

(11) ATT

The ATT (RF attenuator) button provides insertion of a 20 dB attenuator in the incoming signal path to minimize receiver cross modulation caused by extremely strong local signals.

(12) PROC LEVEL/AF GAIN

The PROC LEVEL and AF GAIN controls are mounted on concentric shafts. The PROC LEVEL control allows manual control of the output level of the RF speech processor. The processor is actuated by pressing the silver pushbutton to the left of the PROC LEVEL control.

The AF GAIN control adjusts the audio output level at the speaker and phone jack. Clockwise rotation increases the audio output.

(13) TUNE

This pushbutton, when depressed, places the transmitter in the "tune" condition for ten seconds for tuning purposes. After ten seconds, the transceiver is returned to the receive mode so as to prevent damage to the final amplifier tubes caused by excessive "key down" time during tune-up.

(14) LOADING

This control tunes the output circuit of the pi network to match the antenna/feedline impedance.

(15) PLATE

This control tunes the plate circuit of the final amplifier.

(16) CALIB

When the MARK switch is activated, the CALIB knob provides manual control for zeroing the calibration of the digital display with the calibrator signal.

(17) CARR/KEYER

The CARR and KEYER controls are mounted on concentric shafts. The CARR control varies the amount of carrier in the CW, AM, FSK, and FM models of operation.

The KEYER control varies the speed of the built-in Curtis 8043 IC electronic keyer.

(18) VOX GAIN

This control selects MOX/PTT/VOX transmitter relay control as well as adjusting the sensitivity of the VOX circuitry. The PTT position provides push-to-talk operation from a microphone PTT switch or a footswitch. The MOX position provides manual transmit. It must be returned to the PTT position for receiver recovery.

(19) APF FREQ

This knob, when actuated by turning on the APF switch, provides manual control for peaking the audio peak filter (APF) circuit on the desired signal. This control will find its chief usefulness on CW, because its bandwidth is much too narrow for normal SSB reception.

(20) SQL/MIC GAIN

The SQL and MIC GAIN controls are mounted on concentric shafts. The SQL control sets the squelch threshold level for FM reception.

The MIC GAIN control varies the audio level from the microphone amplifier stage. The control has sufficient range to permit the use of any low impedance (500 - 600 Ohm) crystal or dynamic microphone. Clockwise rotation increases the level of output from the microphone amplifier stage.

(21) FUNCTION SWITCHES: AMGC, APF/MONI, AGC, PO/IC/ALC, and NB/MARK

The AMGC switch activates a microphone gain threshold circuit which requires a particular

minimum input level from the microphone to trigger the microphone amplifier. Low-level background noise will not activate the transmitter with the AMGC in operation. This circuit may be considered a "microphone squelch" system. The M GAIN control functions normally with the AMGC system in operation.

When the APF/MONI switch is in the APF position, the audio peak filter (APF) circuitry is activated. The exact frequency of the audio peak is set by the APF FREQ knob. When this switch is placed in the MONI position, monitoring of the microphone level may be accomplished for operator convenience or tape recording both sides of a QSO. In the CW mode, CW sidetone will be heard regardless of the position of the APF/MONI switch.

The AGC switch controls the length of the recovery time for the receiver AGC circuitry. This switch provides slow or fast recovery, and will also turn off the AGC if desired.

The PO/IC/ALC switch will hereafter be referred to as the METER switch. In the PO position, relative transmitter output power can be observed. In the IC position, transmitter final amplifier cathode current may be measured. In the ALC position, transmitter ALC voltage may be read. When the FT-901DM is in the receive mode, the meter functions as an "S" meter.

The NB/MARK switch provides for actuation of either the Noise Blanker (NB) or crystal calibrator (MARK). The marker oscillator can produce calibration signals at intervals of either 25 kHz or 100 kHz by proper positioning of a switch inside the cabinet.

(22) POWER

This is the main on/off switch for the transceiver. In the OFF position, the memory circuits are disabled, so that when the transceiver is turned to ON again, the memory circuits will have to be reset.

(23) HEATER

With the HEATER switch in the down position, the transmitter tube heaters are turned off. This reduces battery drain to 1.1 amp and thus permits long periods of listening without excessive battery drain. Placing this switch in the up position provides supply voltage to the tube heaters, and after 30 seconds of warmup the transmitter is ready for operation. This switch operates in both the AC and DC modes.

(24) PHONES

This is a standard 1/4" phone jack for accommodation of headphones. The internal speaker is disabled when headphones are plugged into this jack.

(25) MIC

This four-conductor jack accommodates the microphone plug for microphone input as well as for PTT actuation.

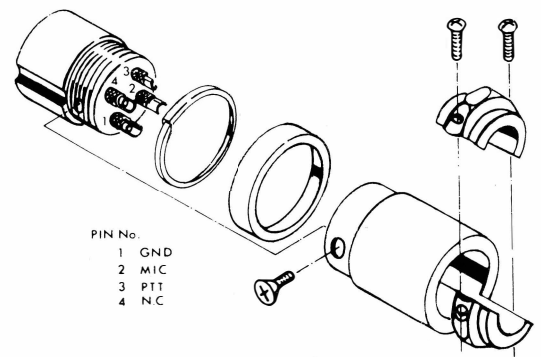
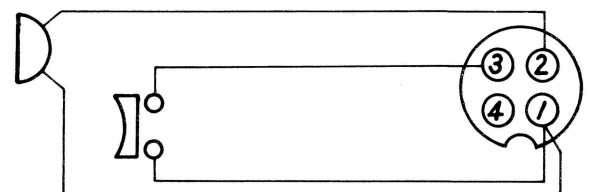

Mic plug

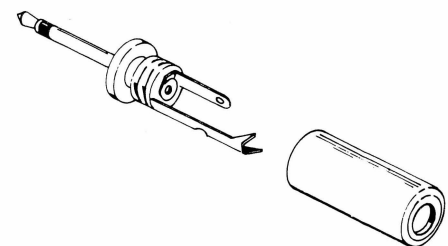
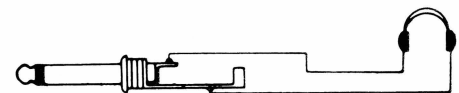

Headphone plug

REAR APRON CONNECTIONS

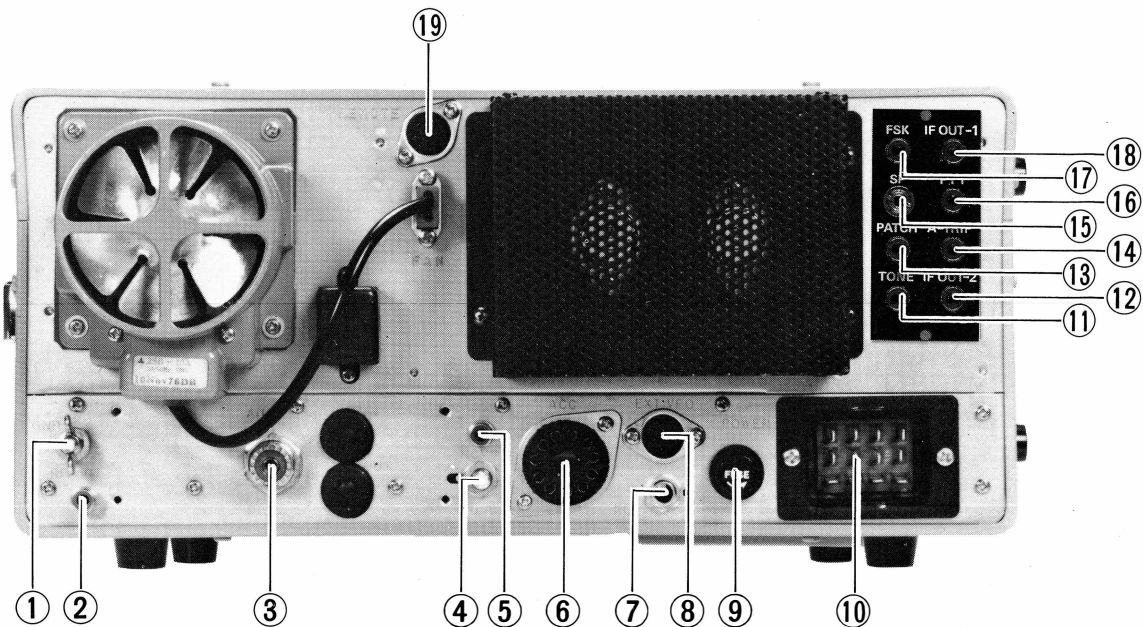

(1) GND

Threaded lug for ground connection.

(2) RF OUT

Signal frequency output from the driver stage may be obtained at this jack for use with optional equipment, such as the FTV-901R VHF/UHF transverter.

(3) ANT

Coaxial connection for antenna.

(4) PO ADJ

Sets PO meter sensitivity.

(5) RCV ANT

A second receiver receives its antenna connection through this jack.

(6) ACC

Accessory socket. Provides access to transceiver operating voltages and relay contacts.

(7) KEY

Three-conductor jack for connection to keyer paddle or external key.

(8) EXT VFO

Connections for external VFO.

(9) FUSE

Fuse holder requires 5 amp fuse for 117 volt or 3 amp fuse for 220 volt operation. For 12 volt DC operation, a 20 amp fuse is installed in the power cable. When replacing fuses, be certain to install a fuse of the proper rating. The warranty does not cover damage caused by improper fuse replacement.

(10) POWER

Power receptacle. Both AC and DC cables are supplied.

(11) TONE

Sidetone output for second receiver (if used).

(12) IF OUT 2

Wide-bandwidth 8.9 MHz IF signal for connection to a spectrum analyzer, etc.

(13) PATCH

Speech input terminal for phone patch connection. Impedance is 500 ohms.

(14) A-TRIP

Anti-trip input from second receiver (if used).

(15) SP

Audio output is provided at this jack for an external speaker. Output impedance is 4 ohms, and

the internal speaker will be disabled when plug is inserted.

(16) PTT

This jack may be used for external actuation of the transmitter. As an example, a footswitch may be connected to this jack to provide remote control of the transmitter relay, leaving the operator's hands free for writing and tuning purposes.

(17) FSK

Input from the FSK terminal may be made through this jack. The FT-901DM is set up for 170 Hz shift.

(18) IF OUT 1

Narrow bandwidth 8.9 MHz IF output is available for use with an IF monitorscope, etc.

(19) REMOTE

Provides switched 13.5 VDC for relay control for external low-pass filter units, etc. As the band-switch is rotated, 13.5 VDC will appear at various pins on the REMOTE jack. Use a VOM to determine the proper pin for the band in use.

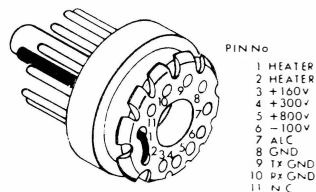

ACC plug

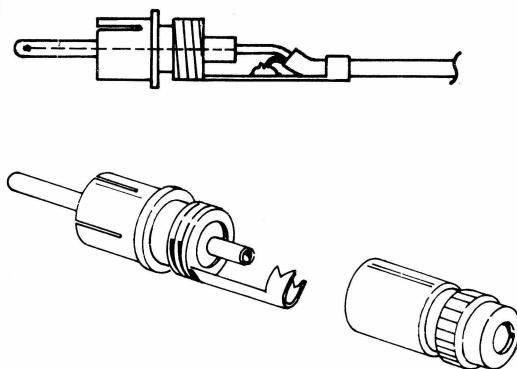

Pin plug

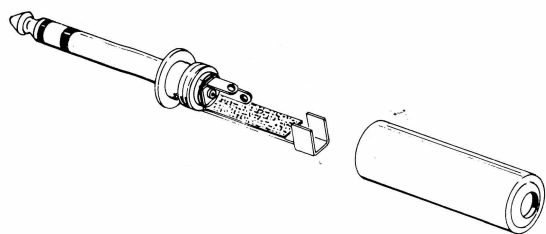
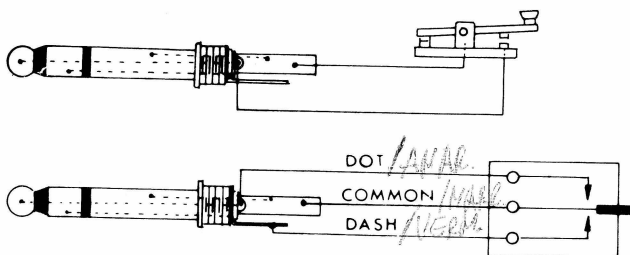

Key plug

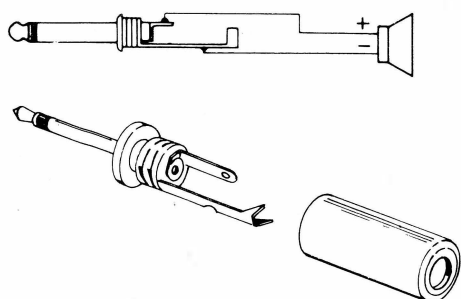

External speaker

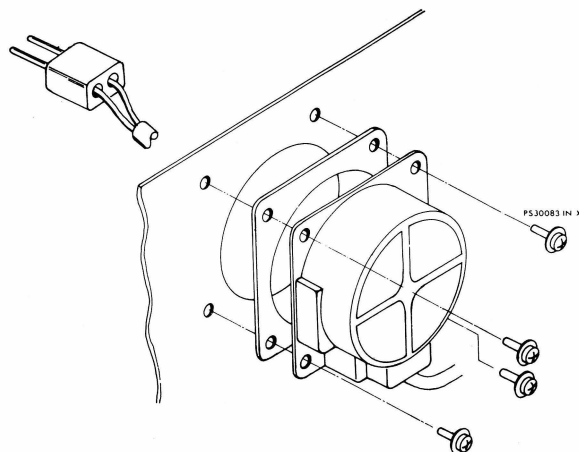

Cooling fan

INTERCONNECTIONS

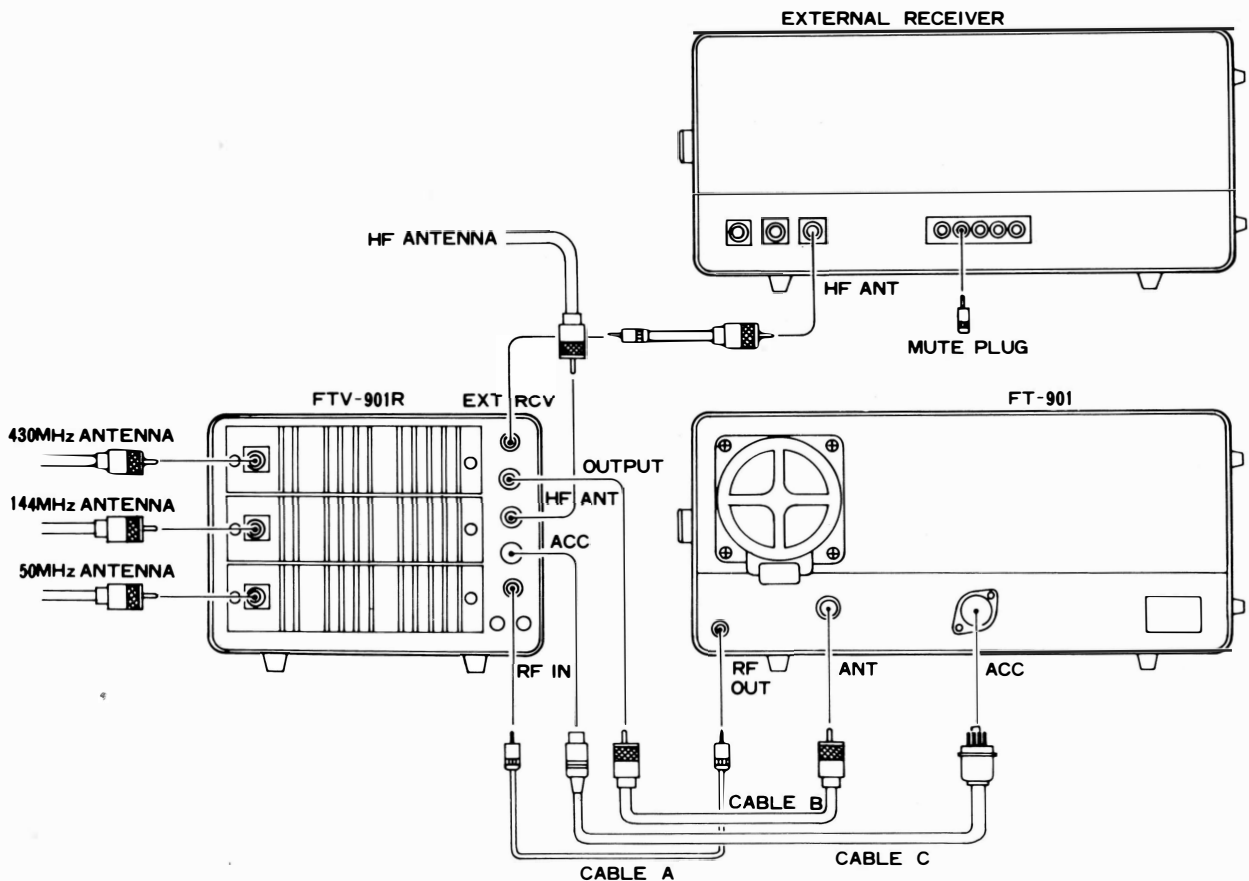
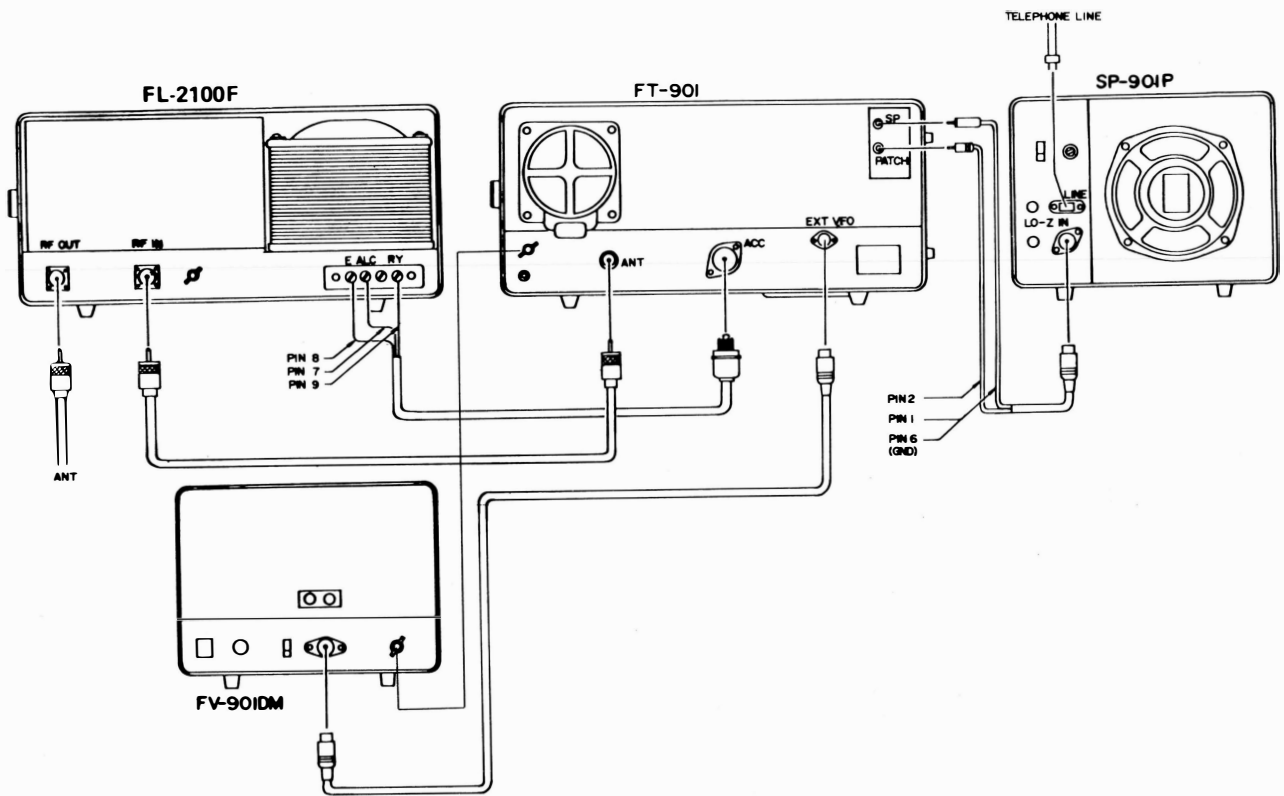

INSTALLATION

This transceiver is designed to be a single-unit station for fixed, portable, or mobile operation. Consequently, power supply connections providing for operation from a variety of source voltages are available. This system provides the flexibility required for changing locations or quick moves from fixed to mobile operation.

BASE STATION INSTALLATION

The FT-901DM is designed for use in many areas of the world using supply voltages that may differ from the operator's local supply voltage. For this reason, be sure that the voltage marked on the rear of the transceiver agrees with the local AC supply voltage. **THIS INSPECTION MUST BE MADE BEFORE CONNECTING THE AC POWER CORD TO THE POWER OUTLET.**

CAUTION

PERMANENT DAMAGE WILL RESULT IF IMPROPER AC SUPPLY VOLTAGE IS APPLIED TO THE TRANSCEIVER.

The transceiver should be connected to a good earth ground. The ground lead should be made with a heavy braid wire and should be connected to the GND terminal on the rear apron of the transceiver.

We do not recommend the use of power connectors other than the ones supplied by Yaesu. If a rig brought in for servicing is blowing fuses every time you plug it in, check to make sure that no "improvements" have been made to the power cord through substitution of or modification to the power connector.

For base station installation, the only important consideration that need be made is to ensure adequate circulation around the unit. Do not place books or papers on or around the cabinet, nor should the unit be placed on top of another heat-generating device such as a linear amplifier. Avoid heat ducts and window locations which are exposed to the hot sun, and you will keep your transceiver running at full speed for a long, long time.

Be certain to ground the transceiver through a heavy, braided cable less than 10 feet long. Cold water pipes in newer houses probably are unsatisfactory as grounding posts; it is much better

practice to use a system of one or more ground rods, with the ground line securely bonded to the ground system.

MOBILE INSTALLATION

(Note: The DC-DC converter described herein is built-in on the FT-901DM, and is an available option on the FT-901D/SD/DE models)

The FT-901DM will operate satisfactorily from any 13.5 Volt DC negative-ground battery source by connecting the DC power cord to the rear panel receptacle. For under-dash mounting, a special mobile mounting bracket is available from your dealer. In mobile installations the transceiver should be suited away from heater ducts. No special precautions need be observed if adequate ventilation spaces is available. A minimum of two inches of air space above the cabinet top and on all sides is recommended to allow proper air flow around the cabinet. Never stack other units above or below the transceiver since the accumulated heat from both units could cause damage.

The transceiver requires an average of 14 amps on transmit, with 20 amps on voice peaks. The DC power cable comes equipped with a 20 amp fuse. When making connections to the car battery, be absolutely certain that the RED lead is connected to the positive (+) terminal and the BLACK lead is connected to the negative (-) terminal. Reversed connections could permanently damage the transceiver.

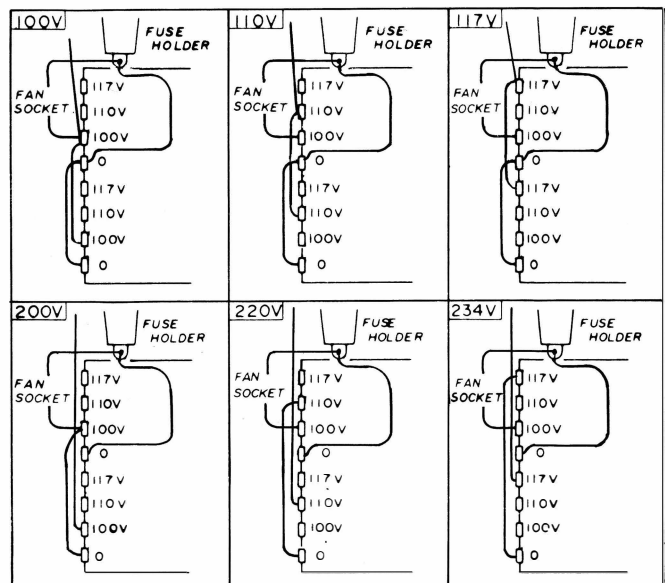

The BLACK lead should, preferably, run directly to the negative terminal of the battery. Using the car frame as a negative connection or connecting the RED lead to a positive point such as the ignition switch places the transceiver in the same current path as noise-creating devices, thus failing to take advantage of the filtering action of the battery. The power cable should be kept away from ignition wires and should be as short as possible to minimize voltage drop and to provide a low impedance path from the transceiver to the battery.

Before connecting the power cable to the transceiver, check the battery voltage with the engine running (battery charging). If the voltage exceeds 15 Volts DC, the regulator should be readjusted so that the highest charging rate does not exceed 15 Volts. The transceiver should always be switched OFF while the car engine is being started to prevent voltage transients from damaging power supply components.

ANTENNA CONSIDERATIONS

The FT-901 transceivers are designed for operation using an antenna system presenting a 50-75 ohm resistive load at the antenna jack. Amateur installations seldom meet this requirement over the entire spread of every band, but the final amplifier pi network is sufficiently forgiving to allow for minor deviations from the target figure. However, significant departures from the 50-75 ohm range will result in seriously degraded transceiver performance.

If an open-wire feedline is used, or if the input impedance of the antenna system presents a very high or very low impedance at the coaxial input, some sort of antenna tuner must be used to provide a 50 - 75 Ohm unbalanced feedpoint for the transceiver.

For mobile operation, most of the commercially-available antennas on the market will provide good results if care is taken to tune the antenna for minimum SWR. The outer conductor of the coaxial cable should be securely grounded to the automobile chassis at the antenna mount.

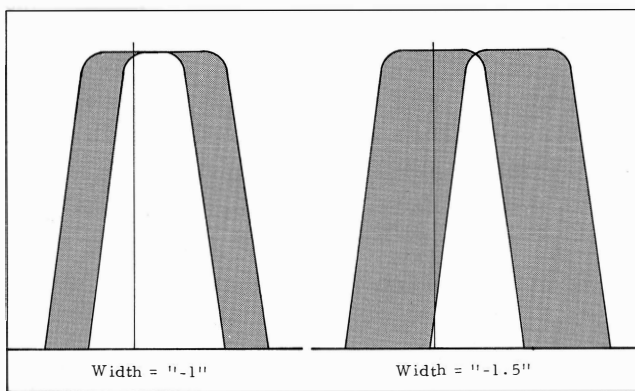

Width Control Action

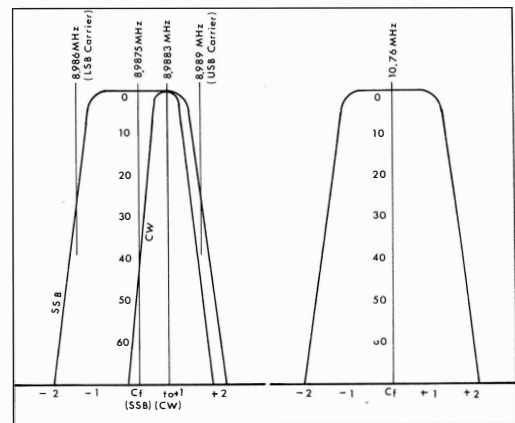

SSB, CW Filters

SSB Filter

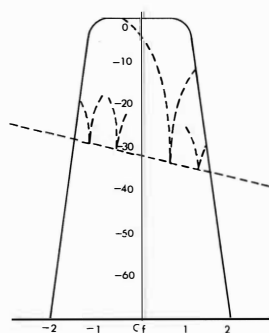

Rejection Tuning Action

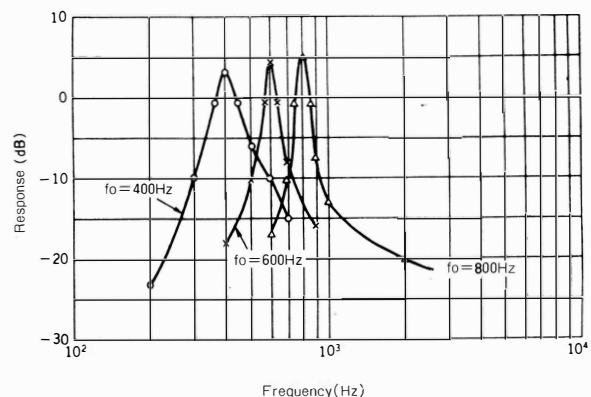

APF Action

OPERATION

The tuning procedure for this transceiver is not complicated. However, care should be exercised when tuning so that peak performance of the equipment is secured. The following paragraphs describe the procedure for receiver and transmitter operation.

INITIAL CHECK

Before connecting the transceiver to a power source, carefully examine the unit for any visible damage. Check that all modules are firmly in place and that the controls and switches are operating normally. Make sure that the voltage specification marked on the rear panel matches your supply voltage, and that the line fuse on the rear panel matches the supply voltage; for 117 VAC, use a 5 amp fuse, and for 220 VAC use a 3 amp fuse. For DC operation a fuse holder is installed in the DC cable, and a 20 amp fuse should be installed here.

FREQUENCY SELECTION

Frequency readout for the FT-901DM includes both analog and digital readout. The analog readout dial shows calibrations at the 100 kHz and 10 kHz points, and is marked, as well, in 1 kHz increments for fine tuning. The digital readout displays all digits of the operating frequency, with resolution down to 100 Hz accuracy.

RECEIVE OPERATION

- (1) Preset the controls and switches as indicated:
POWEROFF
HEATEROFF
VFOSwitch depressed
VOX GAIN . . .PTT position
RF GAIN . . .Fully clockwise
AF GAIN . . .Adjust subsequently for comfortable level
BANDDesired band
MODEDesired mode
PRESELECT . .Desired band segment
- (2) Turn the POWER switch to ON. The meter will light up and the operating frequency will be displayed on the dial window. Adjust the AF GAIN control for a comfortable listening level, and adjust the PRESELECT control for maximum receiver noise or signal level. The PRESELECT control may require repeaking as the main tuning dial is tuned across the band.
- (3) The RX CLARIFIER may be utilized if the received signal is drifting. Pushing the RX button and rotating the CLARIFIER control will provide a means of offsetting the receiver frequency ± 2.5 kHz without changing the transmitting frequency. A red LED indicator will light up when the CLARIFIER is in use.
- (4) When pulse-type noise is encountered, the NB (Noise Blanker) switch should be activated, providing effective suppression of this type of noise.
- (5) Rejection of adjacent-channel interference may be accomplished by several means. The REJECT control may be utilized to place a steep-skirt 30 dB notch attenuation on any interfering signal within the IF passband. The WIDTH control varies the center frequency of one of two IF filters (the other is fixed and presents a boundary for narrowing the passband). Varying the WIDTH control varies the IF selectivity from approximately 300 Hz to 2.4 kHz (at 2.4 kHz the WIDTH control is at "0" and the two filters have the same center frequency). Clockwise rotation from the center ("0") position makes the passband narrow toward the high frequency side, while counter-clockwise rotation narrows the passband on the low-frequency side.
- (6) For CW reception, the APF (Audio Peak Filter) may be activated. This filter has a 100 Hz peak bandwidth with very steep skirts so as to provide single-signal reception for CW, with insertion loss of less than 1 dB when the APF control is tuned exactly to the signal frequency. The APF FREQ control varies the peak frequency from approximately 400 Hz to 900 Hz. The operator will observe that the APF system provides a significant

improvement in signal-to-noise ratio. The selectivity of the APF circuit may be varied by adjusting VR₅₀₁ under the top cover.

- (7) For extremely strong signals, the ATT (RF attenuator) switch may be pressed to activate a 20 dB attenuation of the incoming signal. This should prevent any chance of overload of the receiver front end.

TRANSMITTER TUNE-UP

The following tune-up procedure must be performed prior to commencing operation on the desired mode: LSB, USB, CW, FSK, AM, or FM. See the paragraphs relating to the specific mode after basic transmitter tune-up is described.

Connect a dummy load or matched antenna to the coaxial fitting on the rear apron. Preset the controls as follows:

POWER.....OFF
 HEATER.....OFF
 CARR.....Fully counter-clockwise position
 MIC GAIN.....Fully counter-clockwise position
 AMGC.....OFF
 METER switch . IC
 SELECT.....VFO (Depressed)
 BAND.....Desired band segment
 MODE.....USB or LSB
 PLATE.....Desired band segment
 PRESELECT...Desired band segment
 LOADING.....To position shown in table
 PROC.....OFF (Not depressed)
 TUNE.....OFF (Not depressed)
 CLAR TX.....OFF (Not depressed)
 VOX GAIN....PTT position

Turn the POWER and HEATER switches to ON. From a cold start, allow 60 seconds after the HEATER switch is turned on for warm-up of the transmitter tubes. Be certain that the accessory plug is inserted in the accessory socket; without this plug being so connected, there will be no power applied to the tube heaters. Heater voltage is supplied through pins 1 and 2 of the accessory socket.

LOADING POSITIONS

BAND	POSITION
160	5
80	4
40	3.5
20	3
15	2.5
10A	3
10B	3
10C	3
10D	3

Note: LOADING positions are nominal. Minor variations from positions shown are to be expected.

Set the VOX GAIN control to MOX. The meter will now read final amplifier resting cathode current. This should read .05 (50 mA).* If it is not, adjust the bias control located under the top cover near the rear of the set. Set the METER switch to ALC and adjust the ALC control under the top cover for full scale deflection of the meter. Return the meter switch to IC and the VOX GAIN control to PTT.

*Note: On the FT-901SD, resting cathode current should be .025 (25 mA).

PRE-TUNING

(IMPORTANT NOTE: Subsequent transmitter tuning utilizes the TUNE button instead of MOX for actuating the transmitter. When pressed, the TUNE button causes the transmitter to be activated for ten seconds, after which time the FT-901DM returns to the receive condition. This is a protective feature that should not be nullified by use of the MOX control.)

- (1) Adjust the PRESELECT control for maximum receiver noise level.
- (2) Depress the TUNE button. Rotate the CARR control until the meter reading rises just above the normal idling current of .05 (50 mA).
- (3) Adjust the PRESELECT control for a maximum meter indication.
 Caution: if the meter reading exceeds .1 (100 mA) reduce the setting of the CARR control.

- (4) Rotate the PLATE control for a minimum meter reading ("dip" in final amplifier cathode current).
- (5) Push the TUNE button again to return the transceiver to the receive condition.

FINAL TUNING

Final peak tuning utilizes the relative power output position of the METER switch. At full rated power into a 50 Ohm load, the meter will read approximately 1/2 to 2/3 full scale. If the PO reading is too high (off scale) or too low (1/4 scale or less) and the load impedance is very close to 50 Ohms, the PO ADJ control on the rear apron may be adjusted so as to provide 1/2 to 2/3 scale deflection at full power. Once the PO meter is calibrated, off-scale meter deflections are the result of reflected power due to high SWR, and corrective action may be required in the antenna system.

Final transmitter peaking is described below:

- (1) Set the METER switch to the PO position and rotate the CARR control to the 11 o'clock position.
- (2) Press the TUNE button and rotate the PRE-SELECT control for a maximum meter reading. Press the TUNE button again to return to the receive condition.
- (3) Press the TUNE button and rotate the LOADING control for a maximum meter reading. Press the TUNE button again to return to the receive condition.
- (4) Press the TUNE button and rotate the PLATE control for a maximum meter reading. Press the TUNE button again to return to the receive condition.
- (5) Repeat steps 2 through 4, advancing the CARR control approximately 2 units for each set of adjustments until the CARR control is fully clockwise. The transmitter is now tuned for maximum power output.
- (6) Return the CARR control to the fully counter-clockwise position. Return the METER switch to IC.

With familiarity, some of steps 2 - 4 may be performed within one press of the TUNE button, taking advantage of the 10-second timer. The operator is discouraged, through, from exceeding the 10-second limitation imposed by the timer through use of the MOX position or the microphone PTT switch.

SSB OPERATION

After completion of the above tuning procedure, set the MODE switch to USB or LSB as desired. Set the VOX GAIN control to PTT and activate the transmitter by pushing the microphone PTT switch or the footswitch, if used. While speaking in a normal voice into the microphone, advance the MIC GAIN control until the meter kicks down to the midscale of the green-colored portion of the meter scale.

Note: When the METER switch is set to IC, voice modulation peaks will indicate 150 - 200 mA. Actual peak current, however, is approximately 2 times the indicated value.

To set the sensitivity of the VOX system, begin with the VOX GAIN control in the PTT position. Advance the VOX GAIN and speak in a normal voice. The VOX GAIN control should be advanced until the voice actuates the transmitter (do not press the microphone PTT switch or footswitch, if used, during this adjustment).

Set the antitrip potentiometer under the top cover to the minimum point which prevents the speaker output from tripping the VOX. Do not use more VOX GAIN nor antitrip than necessary. Adjust the delay potentiometer under the top cover for the desired release time.

If desired, the AMGC circuit may be activated. This circuit acts as a "microphone squelch;" that is, it initiates a threshold for microphone input which must be exceeded before output from the microphone amplifier will occur. This feature permits minor noises such as a TV in the operating room to be present without going out over the air. Adjustment of the AMGC delay time is made by a control under the top cover.

RF SPEECH PROCESSOR ADJUSTMENT (All models)

The FT-901DM speech processor, when properly adjusted, is designed to improve the intelligibility threshold at the receiving end by increasing the average SSB power output. RF clipping is applied to the IF signal, which is then filtered to remove harmonics and out of band intermodulation products.

The distortion produced by RF envelope clipping and filtering is less objectionable than that caused by an equivalent amount of audio clipping. RF clipping causes no increase in the peak power output, but it does clip the peaks of the voice waveform so as to increase the average power output.

With the processor switch (located immediately to the left of the PROC LEVEL control) in the OFF position (not depressed), set the METER switch to the ALC position. Speaking at a normal level, set the MIC GAIN control to the level where the meter indication stays in the green portion of the meter scale. Press the processor switch and adjust the PROC LEVEL control to the position where the ALC indication stays in the green portion of the meter scale while speaking in a normal voice. Optimum setting of the MIC GAIN and PROC LEVEL controls may require observation of the transmitted signal using an oscilloscope.

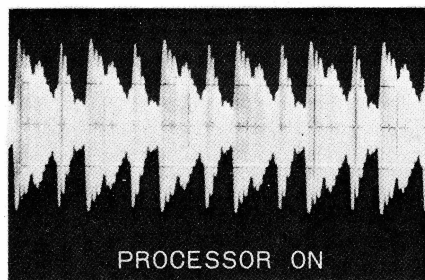
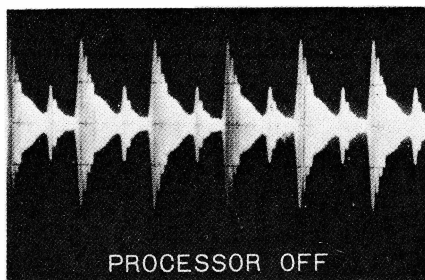

CW OPERATION

Note: The Curtis 8043 IC Keyer Unit is built-in on the FT-901DM/DE, and is an available option on the FT-901D/SD models.

For electronic keyer operation, insert a three conductor plug attached to a keyer paddle into the KEY jack on the rear apron. Keyer speed may then be adjusted by varying the KEYER control on the front panel.

For straight key, bug, or external electronic keyer use, rotate the KEYER control fully counter-clockwise into the click-stop. The desired key line may then be inserted into the KEY jack. Refer to the drawings on page 9 for details of the proper key line plug wiring.

The transmitter may be activated on CW by MOX, PTT, or by VOX (semi-break-in) as desired. The key-up voltage across the key terminals is 7 volts, while the key-down current is 1.5 mA, so most external electronic keyers may be used with the FT-901DM without modification.

The operator may select any power output desired by advancing the CARR control as desired.

NOTE: Insertion of the key plug automatically disconnects the bias supply to the PA tubes. Therefore, bias current will not be indicated when the METER switch is in the IC position.

AM OPERATION

AM operation of the transmitter is accomplished by setting the MODE switch to the AM position and inserting the proper amount of carrier with the CARR control.

After completing basic transmitter tune-up, place the MODE switch in the AM position. Activate the transmitter, and rotate the CARR control until the meter reads .10 (100 mA) in the IC position of the METER switch. While speaking into the microphone in a normal voice, increase the MIC GAIN control until the meter indicates very slight movement with voice peaks. Care must be exercised that the CARR control is not advanced too far. Do not exceed .10 (100 mA) meter indication during AM operation or damage to the transmitter final amplifier tubes may result.

For AM reception, an AM filter is available as an option.

FSK OPERATION

After completing basic transmitter tune-up, place the MODE switch in the FSK position. The FSK terminal input may be connected to the FSK jack

on the rear panel. The FT-901DM is set up for 170 Hz shift, and the shift frequency may be adjusted somewhat by means of the trimmer capacitors located under the top cover. The CARR control must be adjusted in the TUNE position for not more than 100 mA. Excessive cathode current may result in damage to the final amplifier tubes.

Audio output from the transceiver may be taken from the SP jack in the rear apron.

FM OPERATION

Note: The FM Unit is built-in on the FT-901D/DM, and is an available accessory on the FT-901SD/DE models.

After completing the basic transmitter tune-up, set the CARR control for 100 mA carrier level in the FM mode. Speak into the microphone in a normal voice. The MIC GAIN and PROC LEVEL controls have no effect in the FM mode.

For FM reception, the SQL control on the front panel should be advanced only as far as required to silence background noise. When adjusted just past the silencing threshold, the squelch circuitry will provide noise-free reception with maximum sensitivity to weak FM signals.

DIAL CALIBRATION

The frequency readout of the FT-901DM is designed to indicate the carrier frequency. Consequently, there will be a 3 kHz difference between USB and LSB. When calibrating the dial and digital display, the CLARIFIER switch should always be OFF.

- (1) For SSB calibration, place the NB/MARK switch in the MARK position to activate the internal marker signal generator. The choice of 25 kHz or 100 kHz marker intervals may be made by changing the position of switch S₆₀₁, which is located on the VOX unit.
- (2) As the main tuning knob is turned, a beat note will be heard every 25 kHz or 100 kHz, depending on the position of S₆₀₁. Tune the dial and secure a zero beat (lowest pitch frequency) with the marker signal nearest the desired operating frequency.

- (3) Turn the ribbed calibration ring on the main tuning knob shaft to calibrate the analog scale precisely to the zero or 25 kHz point.
- (4) Adjust the CALIB control for a precisely correct reading in the digital window (for example, 14.225.0).
- (5) For CW calibration, secure a zero beat as above, then adjust the CALIB control until the digital display frequency indication is 705 Hz higher than the zero beat (for example, 14.000.7). Then rotate the main tuning dial to secure the zero or 25 kHz reading on the digital display (14.000.0); rotate the ribbed calibration ring on the main tuning knob shaft to align the analog dial precisely with the calibration mark and the digital display. In the CW mode, to repeat, the transmitter carrier frequency is the frequency being displayed.
- (6) In the AM and FM modes, the zero beat signal is not available. Place the WIDTH control in the "0" position, and tune the dial for maximum S-meter indication on the marker signal to establish the calibration point.

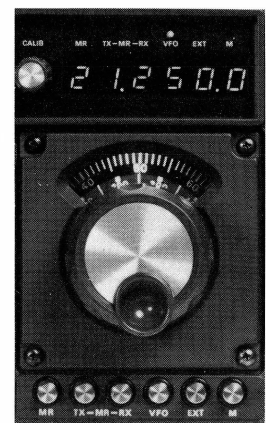
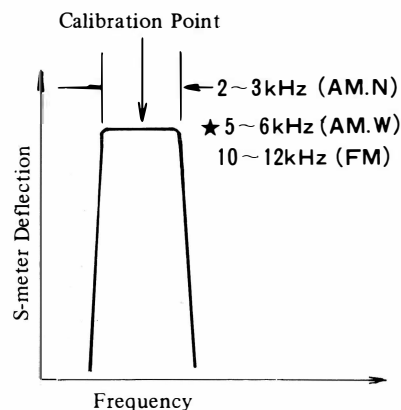

SELECT SWITCHES/MEMORY SYSTEM OPERATION

(Note: The memory unit is built-in on the DM model, optional on the D/SD/DE models)

Frequency control of the FT-901DM is by means of the internal VFO, the memory unit, an external VFO, or various combinations of the three.

Split-frequency control may be obtained with the memory system or the FV-901 synthesized scanning VFO. The switches involved in frequency control are as follows:

- MR This button recalls the memorized frequency for control of the transceive frequency.
- TX MR This button recalls the memorized frequency for control of the transmit frequency.
- RX MR This button recalls the memorized frequency for control of the receive frequency.
- VFO Frequency control is by means of the internal VFO as controlled by the main tuning knob.
- EXT This switch selects the FV-901 synthesized scanning VFO for frequency control as follows: with the EXT and MR buttons pushed, transceive frequency control is by means of the external VFO. With the EXT and TX MR buttons pushed, the external VFO controls the transmit frequency while the internal VFO controls the receive frequency. With the EXT and RX MR buttons pushed, the external VFO controls the receive frequency while the internal VFO controls the transmit frequency.
- M This button is used to store a frequency in memory. THE FREQUENCY DISPLAYED ON THE DIGITAL READ-OUT WILL BE THE FREQUENCY STORED WHEN THE M BUTTON IS PRESSED. When the M button is pressed, the frequency previously stored in memory will be destroyed. When the power is turned off, the frequency is lost from memory.

Note: Because of "round-off error" the digital display and memory system may exhibit a 100 Hz difference between the VFO condition and the memory recall condition.

Operation of the memory system is perhaps best described by the use of some examples:

- (1) You are operating on a net on 3970 kHz and must QSY down 10 kHz to handle a piece of traffic. With the VFO button depressed and the main dial on 3970 kHz, press M; 3970 is now memorized. Move the main dial down to 3960 kHz to handle the message. When finished, press MR for instant return to 3970 kHz. The main dial may be left at 3960 kHz if further QSY to that frequency is anticipated. To return to 3960 kHz, simply press VFO.
- (2) You are operating split frequency on 40 meter phone, and you hear DX1DX on 7090 kHz, listening for calls on 7205 kHz. With the VFO button depressed and the main dial on 7090 kHz, press M to store 7090 kHz in memory, and press RX MR to lock the receiver on 7090 kHz. Turn the main tuning dial to 7205 kHz; you will now be transmitting on 7205 kHz and listening on 7090 kHz. To listen to the pile-up on 7205 kHz of stations calling DX1DX, push VFO; you will now be listening and transmitting on 7205 kHz, and another press of RX MR will return you to 7090 kHz for receive. If DX1DX should begin to drift slightly in frequency, push TX MR and M to store 7205 kHz in memory and lock the transmitter on that frequency. Place the main dial on 7090 kHz for precise tracking of the unstable DX1DX signal.
- (3) You find DX1DX on 21270 kHz, working stations by order of call area. By pressing the M button, 21270 kHz may be stored in memory and the operator may periodically check to see if his call area is being acknowledged by pressing MR or RX MR.

Note: After the M button is pushed, the VCO requires 10 seconds to stabilize on the memorized frequency. If one of the MR buttons is pushed during this 10-second period, some "drifting" of the memorized frequency may be observed.

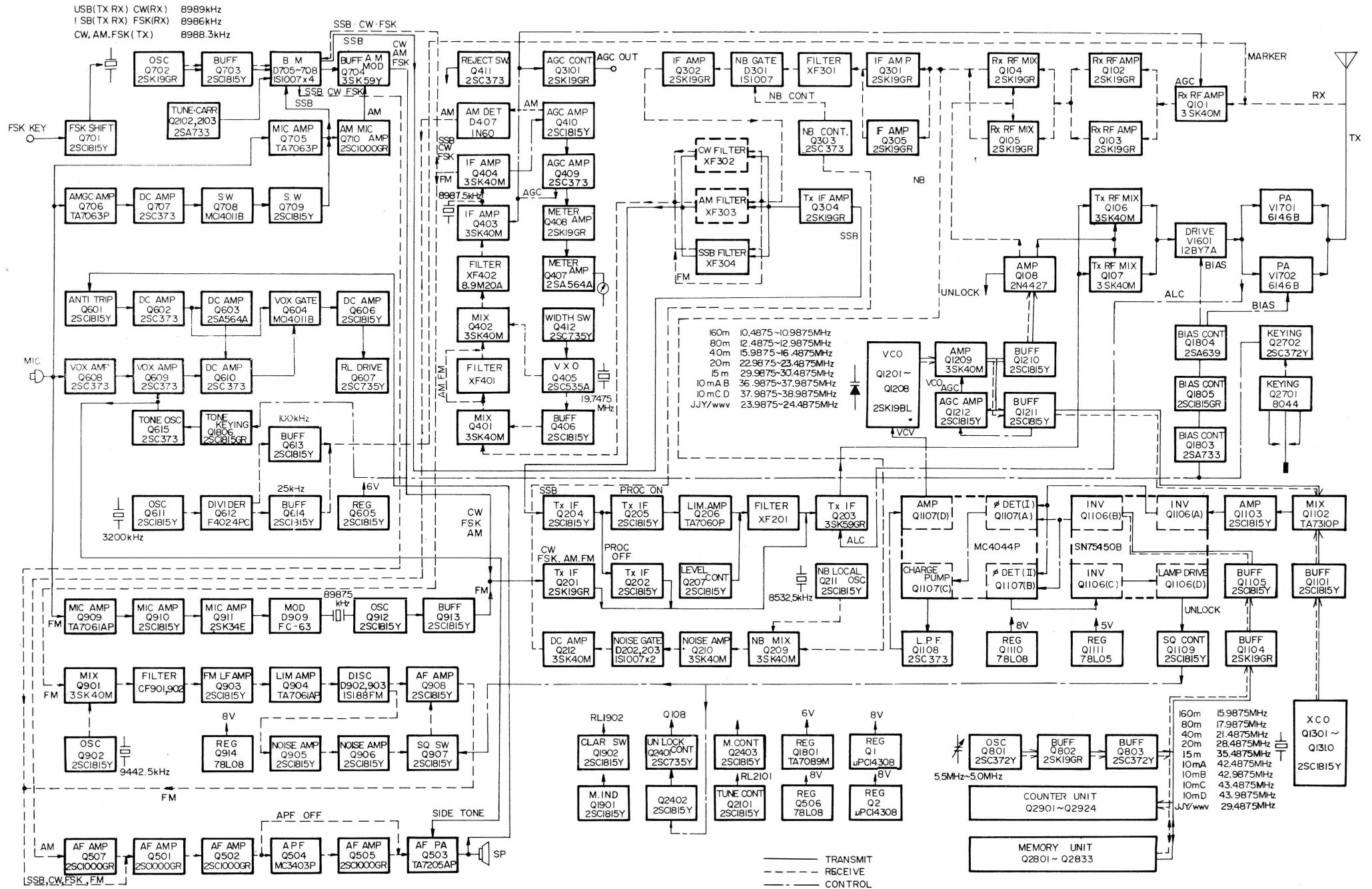

BLOCK DIAGRAM

FT-901 BLOCK DIAGRAM

THEORY OF OPERATION

This transceiver utilizes PLL (Phase Locked Loop) circuitry. The receiver is a single-conversion type with a 8.9875 MHz IF. The following circuit description is tailored to the full-feature FT-901DM, and some of the features and circuitry described below are optional on the FT-901D/SD/DE models.

RECEIVER

The RF input signal from the antenna is fed to pin 3 of the RF UNIT (PB-1702) via antenna relay RL₂, line fuse FH₁, attenuator switch S₂₁₀₃, input transformer T₁, and 9 MHz trap coil T₂₄₀₂.

RF UNIT (PB-1720),

The incoming signal is amplified by the RF amplifier Q₁₀₁ (3SK40M), a dual-gate MOSFET which has superior rejection against cross modulation. The amplified signal is then fed through a source follower by parallel-connected Q₁₀₂ and Q₁₀₃ (both 2SK19GR) to the balanced mixer consisting of Q₁₀₄ and Q₁₀₅ (both 2SK19GR), where the input signal is heterodyned with a local signal delivered from buffer amplifier Q₁₀₈ (2N4427), producing an IF signal of 8.9875 MHz at J₁₀₁.

The input and output of the RF amplifier are permeability tuned circuits, resulting in high sensitivity with excellent rejection of unwanted out-of-band signals.

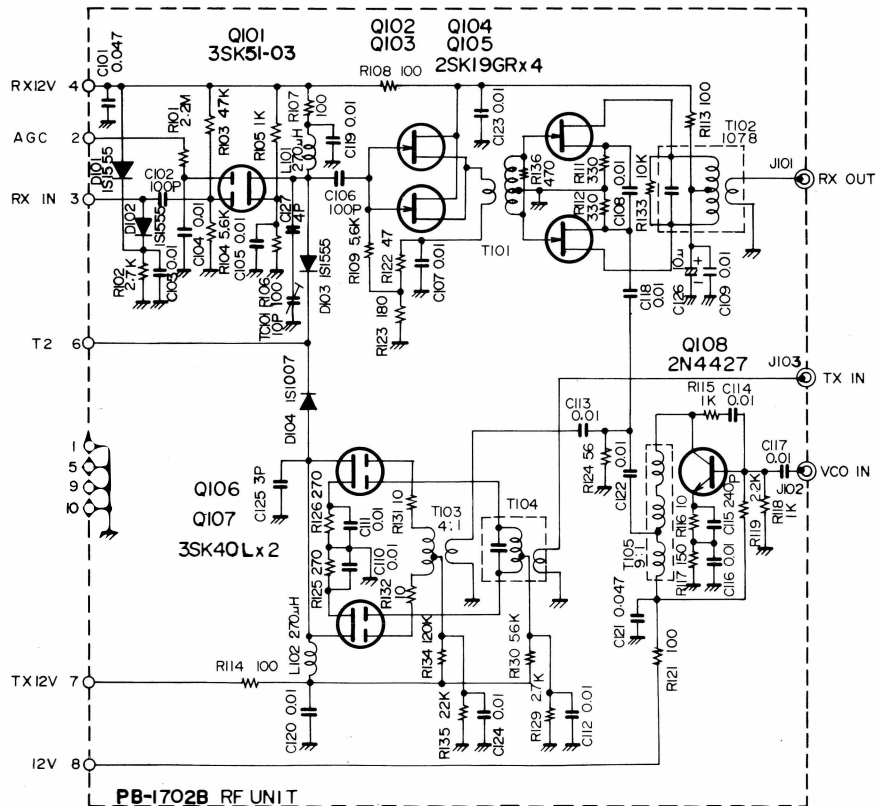

FILTER UNIT (PB-1716C)

The IF signal received at pin 2 of the FILTER UNIT (PB-1716) is amplified by parallel-connected Q₃₀₁ and Q₃₀₅ (both 2SK19GR), and fed through a monolithic filter XF₃₀₁ (8.9M-20A), which has a ± 10 kHz bandwidth, providing additional selectivity and enough delay time to match the noise blanker gating pulses. The signal is then fed to the second IF amplifier, Q₃₀₂ (2SK19GR).

The noise blanker diode D₃₀₁ (1S1007) is placed between T₃₀₂ and T₃₀₃, and it functions as an ON/OFF switch which is controlled by the noise blanker driver Q₃₀₃ (2SC1815Y). The output from the source of Q₃₀₂ is passed through the SSB filter XF₃₀₄ (or the optional AM or CW filters). Selection of the filter to be used is performed by one of the diode switches D₃₀₃ - D₃₀₈ (1S1007), depending on the mode of operation. The IF signal is then transferred to the IF UNIT. In the FM mode, the IF signal is coupled directly through D₃₁₀ (1S1555) to pin 5 of the IF UNIT.

IF UNIT (PB-1704)

The IF signal from pin 14 is fed to the gate of the IF first mixer, Q₄₀₁ (3SK51), where the IF signal is heterodyned with a 19.7475 MHz $\pm \Delta f$ local signal delivered from crystal oscillator Q₄₀₅ (2SC535A) and buffer amplifier Q₄₀₆ (2SC1815Y), resulting in a signal of 10.76 MHz $\pm \Delta f$.

The new 10.76 MHz $\pm \Delta f$ signal is fed through filter XF₄₀₁ to the IF second mixer, Q₄₀₂ (3SK51), where the filtered signal is heterodyned with a 19.7475 MHz $\pm \Delta f$ signal, producing an 8.9875 MHz signal, the same as the original IF. This process moves the IF signal across the passband of XF₄₀₁. The combination of filters XF₃₀₄ and XF₄₀₁ provides continuously variable width of the IF passband.

The frequency of crystal oscillator Q₄₀₅ is varied by varactor diode D₄₀₁ (1S2209).

On the AM and FM modes, the IF signal is passed through diode switches D₄₀₂ and D₄₀₃ (1S1007), and does not pass through filter XF₄₀₁.

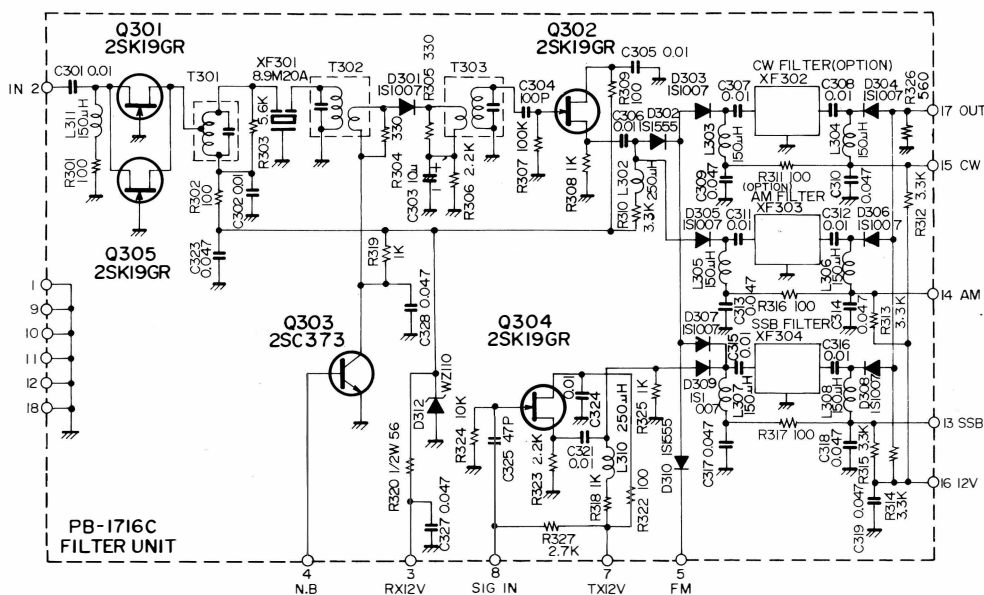

The output from the IF second mixer is fed through a monolithic filter XF₄₀₂ to the two-stage IF amplifier consisting of Q₄₀₃ and Q₄₀₄ (both 3SK40M). The output from Q₄₀₃ is coupled to the rejection tuning circuit which eliminates interference within the IF passband. This rejection function is accomplished by varying the resonant frequency of a crystal with varactor diode D₄₀₆ (1S2209) on the SSB, CW, and FSK modes.

The amplified IF signal is fed to the CARRIER UNIT. In the AM mode, the signal is fed through a buffer amplifier Q₄₁₀ (2SC1815Y) to the AM detector D₄₀₇ (1N60). The signal is then fed to the AF UNIT.

A portion of the output from Q₄₁₀ is rectified by D₄₁₁ and D₄₁₂ (1N60) to produce AGC voltage. The AGC voltage is amplified by DC amplifier Q₄₀₉ (2SC373) and fed to the gate of RF amplifier Q₁₀₁ and to IF amplifiers Q₄₀₃ and Q₄₀₄ to control the gain of these stages for AGC purposes. The time constant of the AGC voltage decay is selectable (FAST/SLOW) by switch S₂₀₀₃. The AGC voltage is further amplified by Q₄₀₈ (2SK19GR) and Q₄₀₇ (2SA564A) for signal strength indication on the front panel S-meter.

The RF GAIN control on the front panel varies the AGC voltage level, providing manual control of the gain of the RF and IF stages.

Q₄₁₁ (2SC373) works as a relay driver for the IF rejection tuning circuit. Delay transistor Q₄₁₂ (2SC735Y) supplies the voltage to the drain of Q₄₀₁ and Q₄₀₂ when the transceiver returns to the receive mode after transmission.

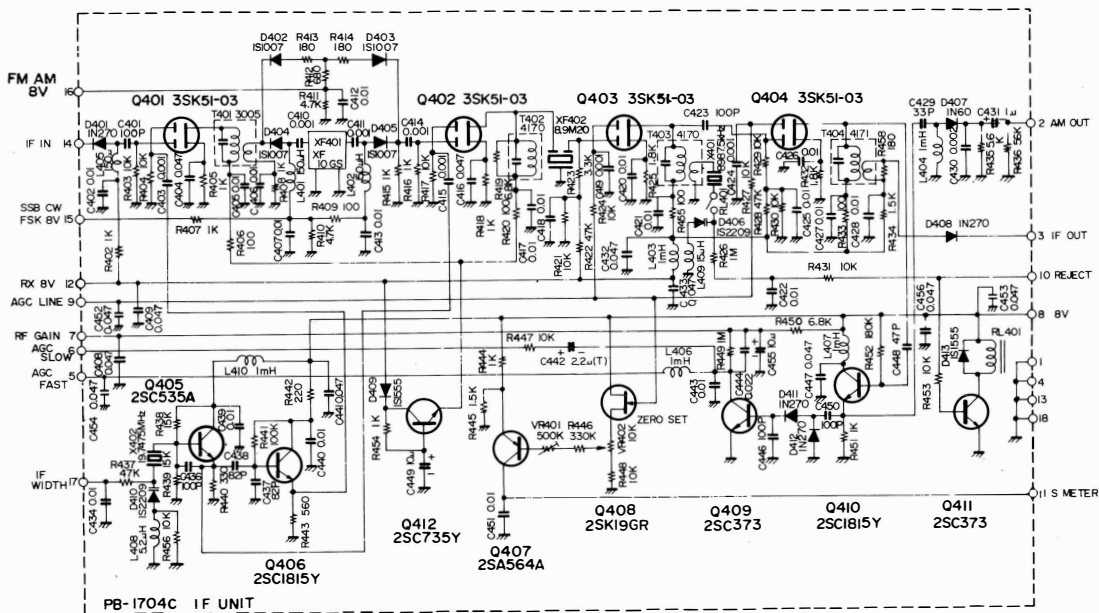
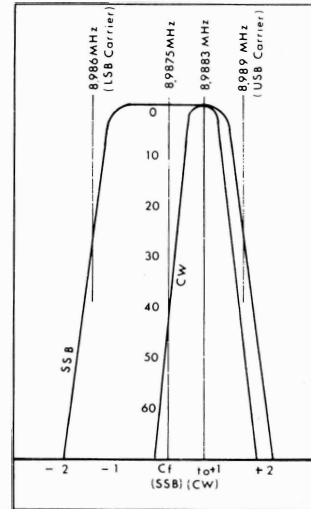

CARRIER UNIT (PB-1706)

The carrier oscillator Q_{702} (2SK19GR) is followed by a buffer amplifier Q_{703} (2SC1815Y). It oscillates at one of the following frequencies, depending on the mode of operation: 8989 kHz with X_{702} ; 8986 kHz with X_{701} ; or 8988.295 kHz with X_{703} . The crystal selection is made by diode switches $D_{701} - D_{703}$ (1S1555).

Diode D_{701} conducts to activate X_{703} , which is used for the CW, FSK, AM, and TUNE transmit signal. Diode D_{702} conducts to activate X_{701} for LSB and FSK reception. Diode D_{703} conducts to activate X_{702} for USB and CW reception.

The carrier signal is fed to the ring demodulator consisting of $D_{705} - D_{708}$ (all 1S1007), which demodulates the IF signal into audio using the carrier signal applied from Q_{703} . The audio is then fed through relay contacts to the AF UNIT.

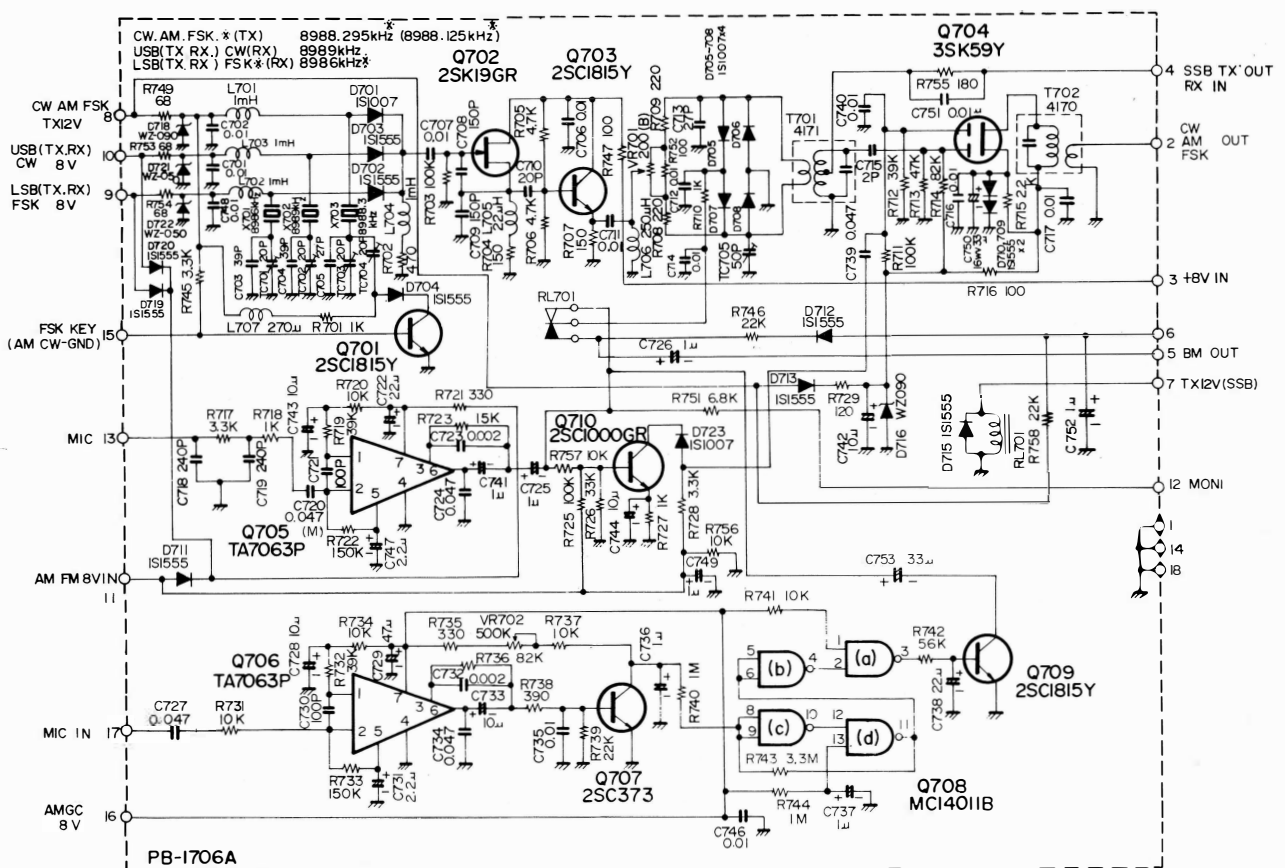

AF UNIT (PB-1705)

The audio signal from the AM detector is amplified by Q₅₀₇ (2SC1000GR) and fed to the first audio amplifier Q₅₀₁ (2SC1000GR). On SSB, CW, FM, and FSK, the audio signal is directly fed to Q₅₀₁ from pin 15. The audio signal is amplified through Q₅₀₁ and Q₅₀₂ (both 2SC1000GR) and is then fed through the APF switch and audio volume control VR₅a to the audio output amplifier Q₅₀₃ (TA7205AP), which delivers 3 watts of audio output to the speaker.

The audio spectrum is shaped by an active low-pass filter of $f_0 = 2.7 \text{ kHz} - 12 \text{ dB/octave}$.

Operational amplifier Q₅₀₄ (MC3403) and AF amplifier Q₅₀₅ (2SC1000GR) are placed into the audio circuit by the APF switch on the front panel. The frequency of this selective amplifier is varied with the front panel APF control VR₄a/b between 400 Hz and 900 Hz, providing single-signal, noise-free CW reception. VR₅₀₁ provides adjustment of the selectivity of the APF circuit.

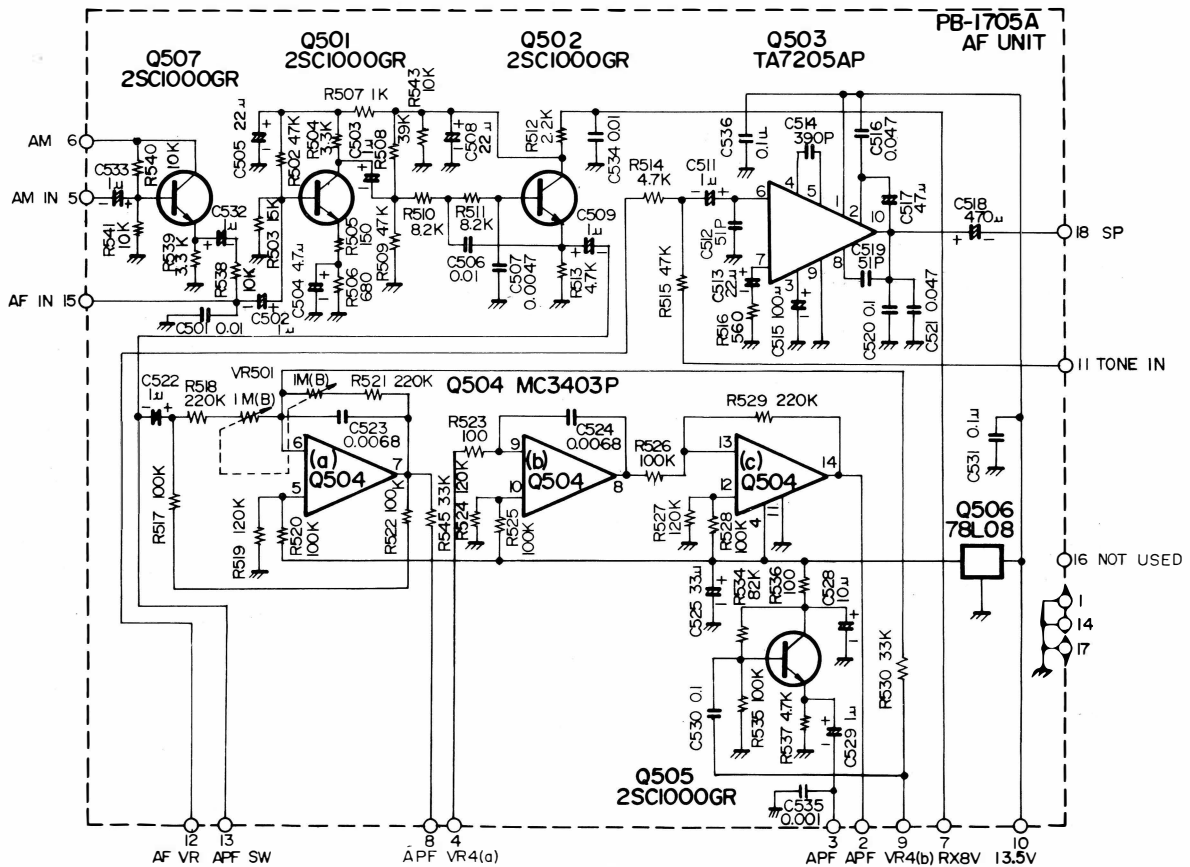

NB UNIT (PB-1703)

A portion of the 8987.5 kHz IF signal is fed to pin 4 of the noise blanker unit and appears at noise blanker mixer Q₂₀₉ (3SK40M), where the 8532.5 kHz signal generated by Q₂₁₁ (2SC1815Y) is mixed with the incoming signal to produce a 455 kHz signal. The 455 kHz signal is then amplified by Q₂₁₀ (3SK40M).

When a carrier or a noise-free modulated signal is received, the 455 kHz signal (with its corresponding strength) is rectified by D₂₀₂ and D₂₀₃ (both 1N60) to charge C₂₃₅. There is no discharge loop for C₂₃₅; therefore, signals which exceed the charged voltage established by the reference voltage on C₂₃₅ will not pass through D₂₀₂ and D₂₀₃. Accordingly, there will be no voltage drop across R₂₄₇, and Q₂₁₂ (3SK40M) will conduct as the gate voltage approaches zero potential. When Q₂₁₂ conducts, the drain voltage at pin 2 of the printed board will drop.

The drain of Q₂₁₂ is directly connected to the base of Q₃₀₃ (2SC1815Y) in the FILTER UNIT. As the drain voltage of Q₂₁₂ drops, the base voltage of Q₃₀₃ drops, turning off Q₃₀₃. The collector voltage will then increase, producing a forward bias to D₃₀₁ (1S1007). As D₃₀₁ conducts, the signals will pass normally through the circuit.

When pulse-type noise is received which exceeds the charged reference voltage established by C₂₃₅, D₂₀₂ and D₂₀₃ will permit negative-going pulses to turn Q₂₁₂ off. The drain voltage will rapidly increase as it turns off.

As the drain voltage increases, Q₃₀₃ will turn on and the collector voltage will decrease. Accordingly, D₃₀₁ will be biased to block the signal. Thus, when pulse-type noise is received, the signal passage will be blanked off momentarily.

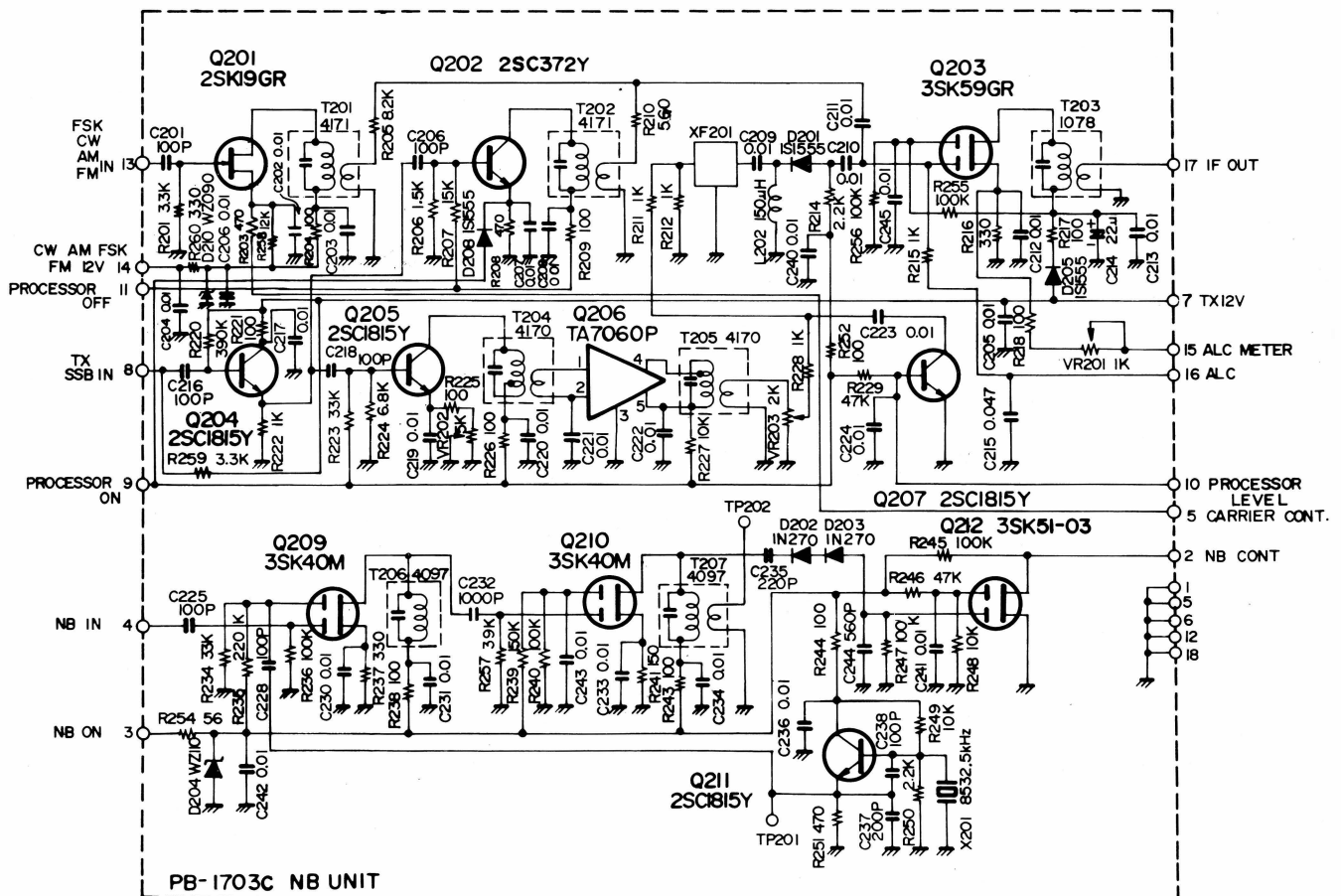

TRANSMIT CIRCUIT

SSB

The output from the MIC jack J₂ is fed through the MIC GAIN control VR_{3a} to pin 13 of the CARRIER UNIT.

CARRIER UNIT (PB-1706)

The microphone signal is amplified by microphone amplifier Q₇₀₅ (TA-7063P) and fed through relay RL₇₀₁ to the ring modulator, consisting of D₇₀₅ - D₇₀₈ (all 1S1007), where the signal modulates a carrier signal delivered from Q₇₀₃ (2SC1815Y). The double sideband signal is fed through T₇₀₁ to the FILTER UNIT.

FILTER UNIT (PB-1716)

The 8987.5 kHz signal fed to pin 8 of the FILTER UNIT is amplified by buffer amplifier Q₃₀₄ (2SK 19GR) and is passed through sideband filter XF₃₀₄ by diode switches D₃₀₉ (1S1555) and D₃₀₇ - D₃₀₈ (both 1S1007) where the DSB signal is converted to an SSB signal by removing the unwanted sideband.

NB UNIT (PB-1703)

The SSB signal is fed through a buffer amplifier Q₂₀₄ (2SC1815Y) to the bases of Q₂₀₂ and Q₂₀₅ (both 2SC1815Y). When the RF processor switch is "OFF," the SSB signal is amplified by Q₂₀₂ and fed to Q₂₀₃ (3SK59GR). When the processor switch is "ON," the SSB signal is amplified by Q₂₀₅ (2SC1815Y) and is further amplified by the limiter Q₂₀₆ (TA7060P), where the signals that exceed the preset clipping level are sliced out. VR₂₀₃ is used to equalize the level of the clipped and unclipped signals.

This highly clipped SSB signal is passed through a selective filter XF₂₀₁ to remove RF harmonics that result from signal clipping. The filtered output signal is amplified by Q₂₀₃ and fed to the RF UNIT. The PROC LEVEL control VR_{5b}, located on the front panel, varies the resistance

between the collector and emitter of Q₂₀₇ (2SC 1815Y), thus changing the input signal level to the filter.

The CW, FSK, AM, and FM signals pass through Q₂₀₁ (2SK19GR) and are fed to Q₂₀₃.

The ALC (Automatic Level Control) voltage detected at the grid circuit of the PA tube is fed to the first gate of Q₂₀₃ to reduce the gain of the amplifier, thus preventing overloading and distortion.

RF UNIT (PB-1702)

The SSB signal from J₁₀₂ of the printed board is fed to the balanced mixer consisting of Q₁₀₆ and Q₁₀₇ (both 3SK40M), where the SSB signal is heterodyned to the desired RF frequency by mixing with the local signal which is supplied from the VCO UNIT. The mixer output is applied through diode switch D₁₀₄ (1S1555) to the DRIVE UNIT.

DRIVE UNIT (PB-1714) PA UNIT (PB-1715)

The output from the RF UNIT is fed to the grid of the transmitter driver V₁₆₀₁ (12BY7A) where it is amplified to a level sufficient to drive the final amplifier tubes V₁₇₀₁ and V₁₇₀₂ (6146B). A portion of the RF signal is coupled through C₁₆ to the cathode of the 12BY7A driver tube so as to improve the linearity of the final amplifier stage (RF negative feedback).

Neutralization of the power amplifier is accomplished by feeding back a small amount of the output through TC₁ to the cold end of the T₃/L₉ combination. The return of the grid circuit is connected to the REC A UNIT (PB1708) to produce ALC voltage to control the gain of the TX IF amplifier, thus preventing distortion caused by overdrive.

CW

In the CW, AM, and FSK modes, carrier oscillator Q₇₀₂ (2SK19GR) on the CARR UNIT generates a crystal controlled carrier signal of 8988.2 kHz. The carrier is fed through buffer amplifier Q₇₀₃ (2SC1815Y) to the ring modulator. Q₇₀₂ also oscillates for TUNE operation.

DC voltage is applied through diode switch D₉₁₂ (1S1555) and RL₇₀₁, to unbalance the ring modulator for CW, AM, and FSK operation; the resulting carrier signal is fed to T₇₀₁.

The output from T₇₀₁ is amplified by Q₇₀₄ (3SK59Y) and fed to Q₂₀₁ (2SC1815Y) on the NB UNIT. The signal is then further amplified by Q₂₀₃ (3SK59GR), and is fed to the transmitter mixer.

Keying of the transmitter is accomplished by changing the bias voltage to V₁₆₀₁, V₁₇₀₁, and V₁₇₀₂. The tubes are cut off on "key up" by application of -35V for V₁₆₀₁ and -110V for V₁₇₀₁ and V₁₇₀₂. These cutoff voltage are reduced to -0.1V and -60V, respectively, during "key down" conditions.

The key is connected to pin 13 of the REC C unit (PB1717). Under "key down" conditions, the base of Q₁₈₀₃ (2SA733) is grounded, causing Q₁₈₀₅ (2SC1815GR) and Q₁₈₀₄ (2SA639) to conduct. The voltage at pin 16 of PB-1717 reaches zero when Q₁₈₀₄ conducts. Since pin 16 of PB-1717 is connected to pin 2 of the RECT A UNIT (PB-1708), the bias voltage of V₁₆₀₁, V₁₇₀₁, and V₁₇₀₂ places these tubes in the normal operating condition.

On other modes, 12 volts is applied to pin 15, causing Q₁₈₀₄ to conduct, thus placing the operating bias on the tubes.

KEYER UNIT (PB-1728)

The built-in electronic keyer utilizes Q₂₇₀₁ (Curtis 8044 IC). The output of Q₂₇₀₁ is high during "key down" conditions; this output is connected to the base of Q₂₇₀₂ (2SC1815Y), the collector current of which is connected to the base of Q₁₈₀₃, causing Q₁₈₀₃ to conduct during "key down" conditions.

Keyer speed is controlled by VR_{2b} on the front panel. VR₂₇₀₁ provides adjustment of the dot-space symmetry, while VR₂₇₀₂ adjusts the keying weight. VR₂₇₀₂ normally is set to minimum, providing a 1:1 dot: space weight.

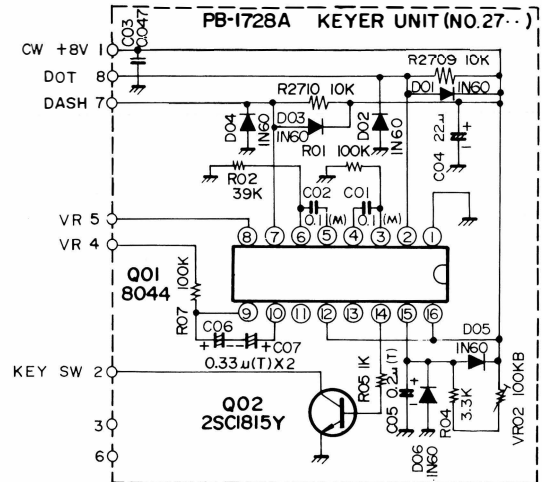

AM

The microphone signal is amplified by Q₇₀₅ (TA7063P) and Q₇₁₀ (2SC1000GR) and fed to Q₇₀₄ (3SK59Y), where it modulates the 8988.2 kHz carrier signal. The output from T₇₀₂ is fed to the NB UNIT in the same manner as described in the CW section previously.

FSK

The carrier oscillator Q₇₀₂ (2SK19GR) generates a crystal controlled carrier frequency of 8988.2 kHz. When keying is applied to the FSK jack J₁₅, the base voltage of Q₇₀₁ (2SC1815Y) becomes zero, causing Q₇₀₁ to cut off. In the "space" condition, Q₇₀₁ conducts, placing TC₇₀₄ in the circuit and lowering the carrier frequency to 8988.03 kHz.

AMGC circuit

The AMGC circuit is located in the CARRIER UNIT and is used to reduce the gain of the microphone amplifier when only low-level background noise is present (no speech input from the opera-

tor). The microphone signal is fed to pin 17 of the CARRIER UNIT, amplified by Q₇₀₆ (TA 7063P), and fed to Q₇₀₇ (2SC373). When a sufficient level of speech input is applied to the microphone, Q₇₀₇ conducts, causing the output of NAND gate Q₇₀₈ (MC14011B) to be "low." This condition cuts off AMGC controller Q₇₀₉ (2SC1815Y). The collector circuit of Q₇₀₉ is connected with the output circuit of the microphone amplifier Q₇₀₅.

When the microphone input signal becomes significantly lower than the normal speech level (background noise only), Q₇₀₇ turns OFF, causing the output of Q₇₀₈ to be "high." This condition causes Q₇₀₉ to conduct, grounding the output circuit of Q₇₀₅.

The gate holding time can be adjusted by means of VR₇₀₂, to allow for differences in operator preferences.

VOX UNIT PB-1846 (PB-1685-3330)

A portion of the microphone input is delivered to pin 10 of the VOX UNIT. The signal is amplified by Q₆₀₈ and Q₆₀₉ (2SC373) and fed to the base of Q₆₁₀ (2SC373). When the signal is applied, Q₆₁₀ conducts, causing C₆₂₁ to discharge. The DC voltage of C₆₂₁ is then fed to the gate circuit of Q₆₀₄ (MC14011B). When pins 1 and 2 of Q₆₀₄ are high, the output of the VOX gate of Q₆₀₄ becomes low, causing Q₆₀₆ (2SC1815Y) to cut off, thus turning relay driver Q₆₀₇ (2SC735) ON to actuate the VOX relay RL₁.

The antitrip circuit provides a bucking voltage to prevent the speaker output from tripping the transceiver into the transmit condition. The receiver audio output is fed through ANTITRIP control VR₆₀₁ to amplifier Q₆₀₁ (2SC1815Y) and is then rectified by D₆₀₁ (1N60). The rectified DC voltage turns Q₆₀₂ (2SC373) ON, placing its collector at a low level, thus preventing the gate circuit from activating the relay driver Q₆₀₇. The collector of Q₆₀₂ is connected through R₆₀₈ to the base of Q₆₀₃ (2SA564A) which shorts the supply voltage for C₆₂₁; thus, C₆₂₁ is fully charged when the speaker output disappears, turning the gate into the transmit mode immediately with the appearance of microphone input.

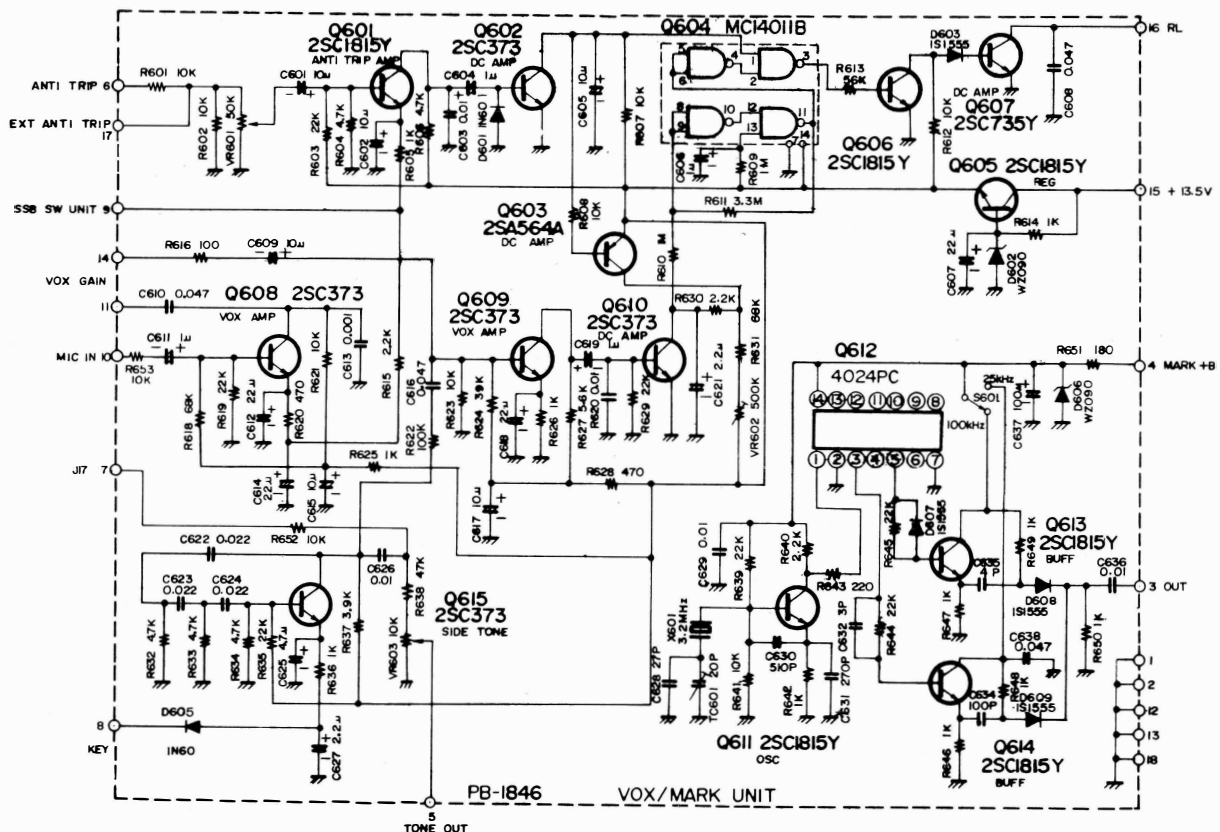

The VOX GAIN control VR_1 on the front panel provides adjustment for relay sensitivity, and VR_{601} controls antitrip sensitivity. Relay hold time is determined by delay control VR_{602} .

The tone oscillator Q_{615} (2SC373) operates when the MODE switch is in the CW position. It is a phase shift oscillator operating at approximately 800 Hz. The sidetone level is adjusted by VR_{603} . The sidetone output is also coupled to the VOX circuit for semi-break-in operation.

Located on the VOX UNIT, the crystal marker generator Q_{611} (2SC1815Y) generates a basic 3200 kHz crystal controlled signal which is divided into 100 kHz multiples by frequency divider Q_{612} (4024PC). The voltage regulator Q_{605} (2SC1815Y) regulates the supply voltage to the VOX circuit.

FM UNIT (PB-1707)

The speech signal from pin 20 of PB-1707 is fed to amplifier limiter Q_{909} (TA7061AP), which clips both positive and negative peaks when they exceed the level set for maximum deviation of the transmitter frequency. Q_{910} (2SC1815Y) acts as

an active low pass filter to eliminate harmonics caused by the clipping. VR_{902} determines the maximum deviation.

The output from Q_{901} is amplified by Q_{911} (2SK34E) and then fed to the modulator D_{909} (FC63). Q_{912} (2SC1815Y) oscillates at a crystal frequency of 8987.5 kHz and is frequency modulated by varactor diode D_{909} . The output from Q_{912} is amplified by Q_{913} (2SC1815Y) and then fed to the NB UNIT.

TUNE UNIT (PB-1720)

When TUNE switch S_{2101} is pushed, the voltage across C_{2101} is applied to the base of Q_{2101} (2SC1815Y), causing Q_{2101} to turn ON; this activates RL_{2102} which grounds the cathodes of D_{2105} and D_{2106} (both 1S1555). As D_{2105} is connected in parallel with the PTT switch, the transceiver is placed in the transmit mode.

Diode D_{2106} grounds the common terminal of the MODE switch S_{2g} and S_{2h} , and the bias voltage of the PA stage is lowered from the cut-off condition to the normal operating level.

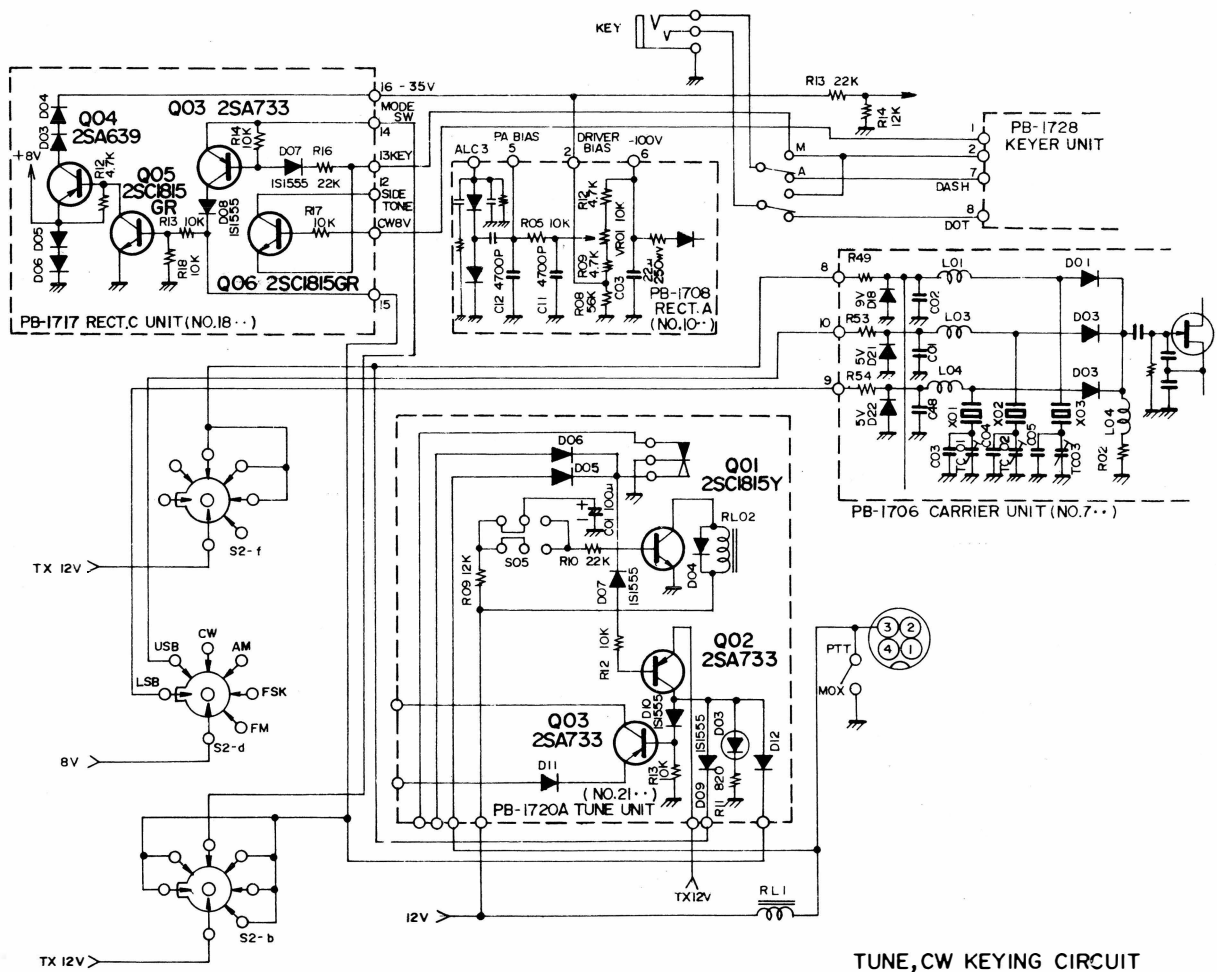

When D_{2107} is grounded, D_{2102} (2SA733) turns ON, and the voltage appearing at the collector of Q_{2102} is fed through D_{2109} (1S1555) to D_{701} on PB-1706 to activate the CW carrier oscillator. In the SSB mode, the SSB carrier oscillator is disabled by reverse voltage.

COMMON CIRCUITS

VFO UNIT (PB-1440A-3330)

A modified Colpitts-type oscillator is used to generate a 5.0 - 5.5 MHz signal, producing a 500 kHz tuning range. The frequency is varied by VC_{801} , which is geared to a precision-built dial tuning mechanism. VC_{801} consists of two sections. The sub-blades compensate for the capacitance variation of the main blades which may result from extreme temperature change.

Varactor diode D_{801} (1S2236) is in series with C_{807} , and the combination of the two is in parallel with TC_{801} . By closing the CLARIFIER switch, the VFO frequency may be varied ± 2.5 kHz with the CLARIFIER control on the front panel.

The oscillator output signal is fed through the amplifier/buffer stage Q_{802} (2SK19GR) and Q_{803} (2SC372Y), and then passes through the low-pass filter to the output terminal.

XTAL UNIT (PB-1711)

Crystal oscillator $Q_{1301} - Q_{1310}$ (all 2SC1815Y) produces a heterodyne signal for the PLL (Phase Locked Loop) mixer. The oscillator frequency is selected by the BAND switch, and the output signal is fed through diode switch $D_{1301} - D_{1310}$ (all 1S1555) to the PLL UNIT. The frequency of each crystal is shown in Table 1.

VCO UNIT (PB-1710)

The VCO (Voltage Controlled Oscillator) generates a heterodyne signal which is 8.9875 kHz higher than the operating frequency. The frequency is locked by the voltage detected by the PLL UNIT.

$Q_{1201} - Q_{1208}$ (all 2SK19BL) oscillate at the frequency given in Table 1. The frequency is locked by varactor diodes $D_{1201} - D_{1208}$ (all MV104), which are controlled by the VCV voltage supplied from the PLL UNIT. The oscillator output signal is amplified by Q_{1209} (3SK40M) and fed to the buffer/amplifier consisting of Q_{1210} and Q_{1211} (both 2SC1815Y). The output from Q_{1210} is fed to the transceiver mixer in the RF UNIT; the output from Q_{1211} is fed to the PLL UNIT as a sample signal.

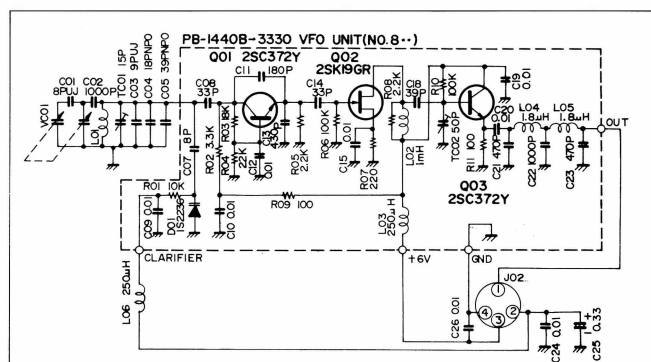

	Crystal Oscillator	V C O
160m	15.9875 (MHz)	10.4875 ~ 10.9875 (MHz)
80m	17.9875	12.4875 ~ 12.9875
40m	21.4875	15.9875 ~ 16.4875
20m	28.4875	22.9875 ~ 23.4875
15m	35.4875	29.9875 ~ 30.4875
10mA	42.4875	36.9875 ~ 37.9875
10mB	42.9875	
10mC	43.4875	37.9875 ~ 38.9875
10mD	43.9875	
JJY/WWV	29.4875	23.9875 ~ 24.4875

Table 1

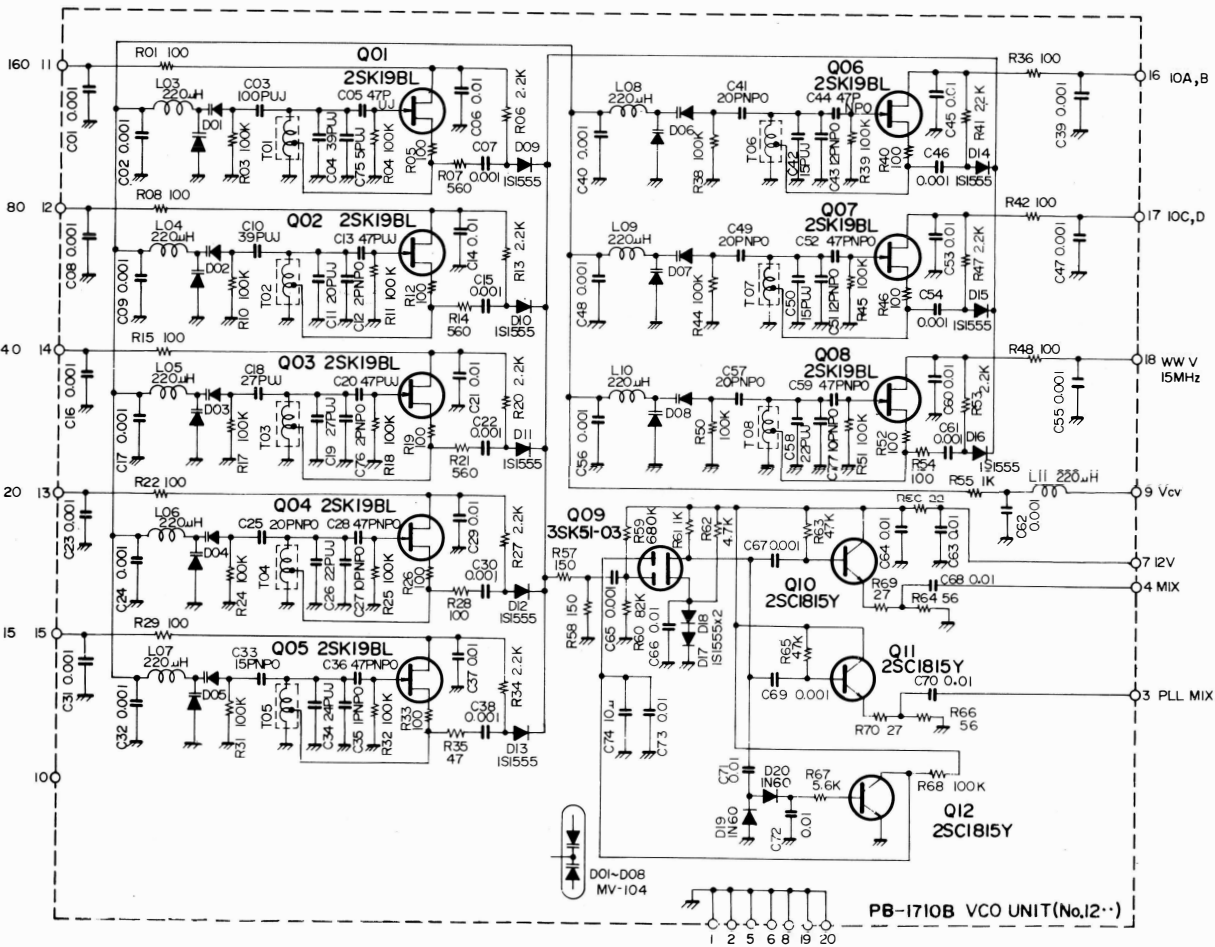
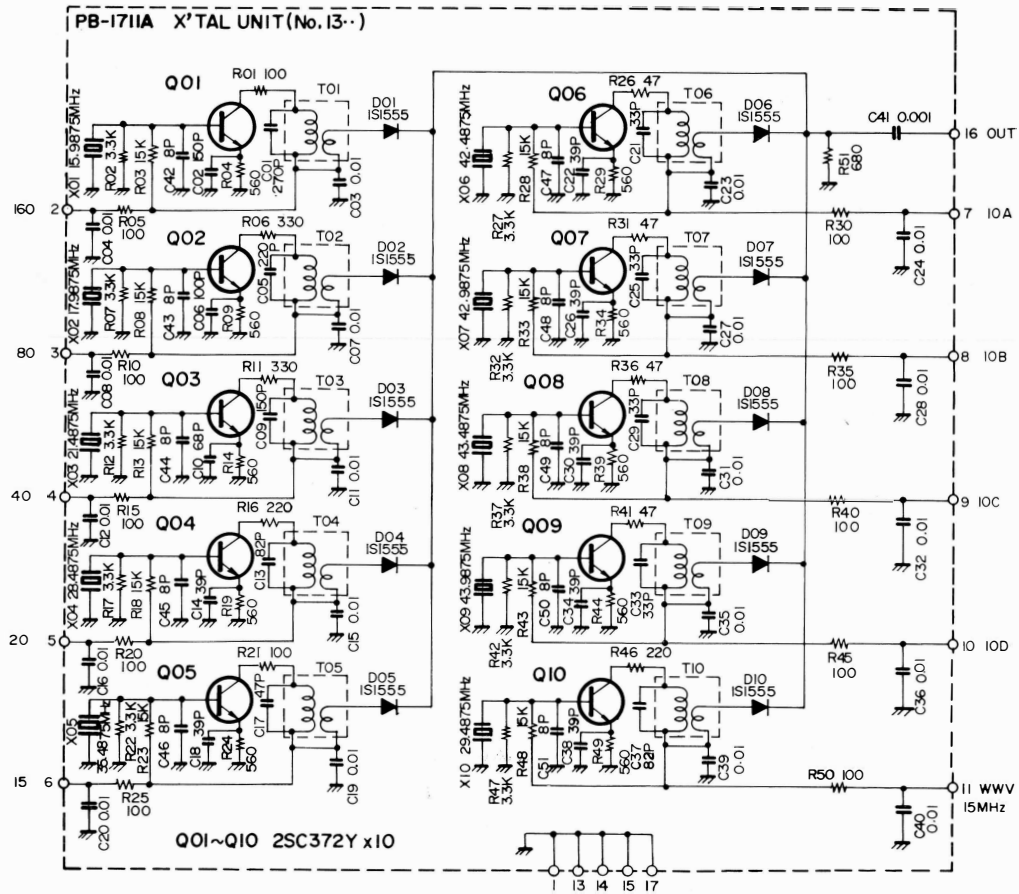

A portion of the Q₁₂₀₉ output is rectified by D₁₂₁₉ and D₁₂₂₀ (both 1N60); this rectified DC voltage is amplified by DC amplifier Q₁₂₁₂ (2SC 1815Y) to generate AGC voltage which controls the gain of Q₁₂₀₉, thus obtaining unity signal output when the band is changed.

PLL UNIT (PB-1709)

The sample signal from the VCO UNIT is fed to the PLL mixer Q₁₁₀₂ (TA7310P), where the sample signal is mixed with the heterodyne signal (at 5.0 - 5.5 MHz) delivered from the XTAL UNIT through buffer amplifier Q₁₁₀₁ (2SC 1815Y). The 5.0 - 5.5 MHz signal is fed through amplifier Q₁₁₀₃ (2SC1815Y) to Q₁₁₀₆ (SN 75450B), where the signal waveform is shaped

prior to being supplied to a phase detector Q₁₁₀₇ (MC4044P); here the phase of the signal is compared with the phase of the signal delivered through wave shaper Q₁₁₀₆, buffer Q₁₁₀₅ (2SC 1815Y), and amplifier Q₁₁₀₄ (2SK19GR) from the VFO UNIT.

Q₁₁₀₇ compares the phase of the two signals and converts the phase difference into the VCV voltage which controls the VCO frequency. Q₁₁₀₈ (2SC 373) acts as an active low pass filter to remove ripples from the VCV voltage.

When the VCO is unlocked, Q₁₁₀₉ (2SC1815Y) delivers the signal to prevent receive or transmit action of the transceiver.

Q₁₁₁₀ (78L08) and Q₁₁₁₁ (78L05) are voltage regulators.

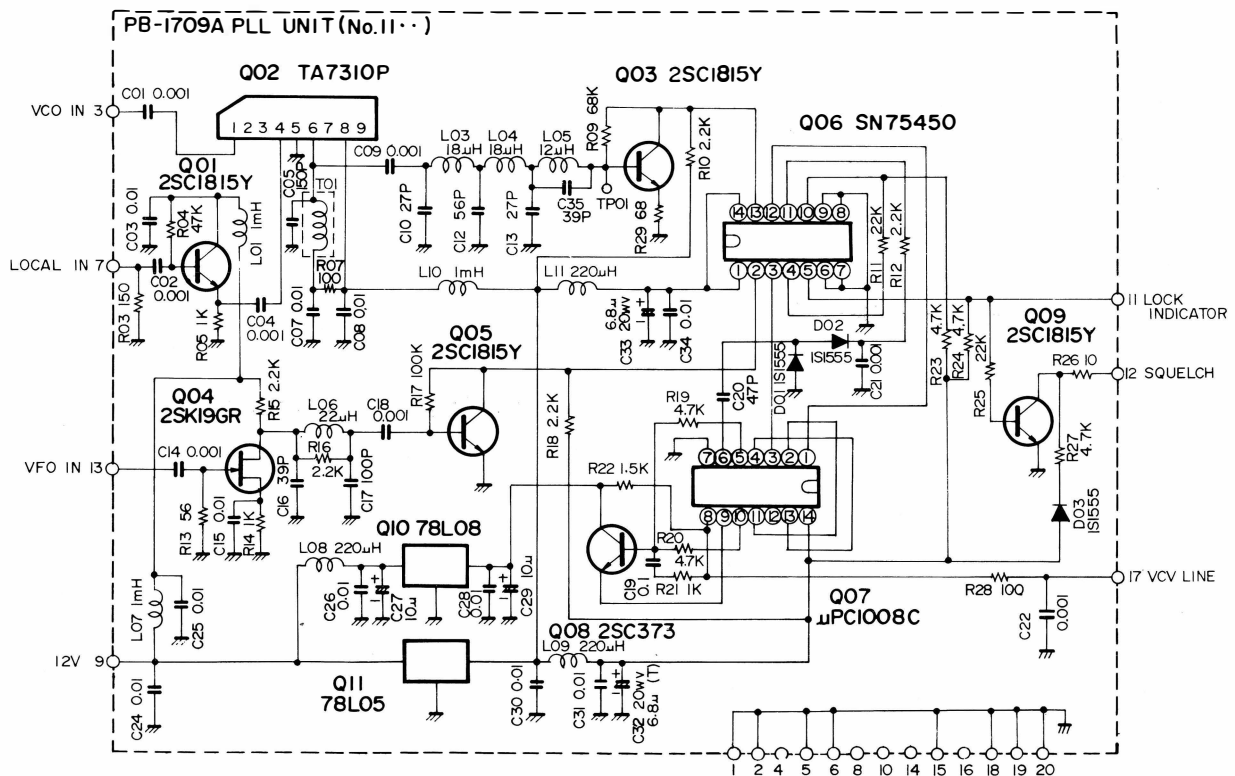

COUNTER UNIT (PB-1729)

DISPLAY UNIT (PB-1730)

The 5.0 - 5.5 MHz VFO signal is amplified by Q₂₉₀₁ (3SK40M) and fed through source follower Q₂₉₀₂ (2SK19GR) to a balanced mixer Q₂₉₀₃ (SN76514N), where the signal is heterodyned with either an 18.0 MHz or 18.5 MHz signal, producing either a 12.5 - 13.0 MHz or 13.0 - 13.5 MHz signal. The oscillator Q₂₉₀₇ (2SC945) generates an 18.0 MHz signal for the 160, 80, 10B, and 10D bands, and Q₂₉₀₆ (2SC945) generates an 18.5 MHz signal for the 40, 20, 15, 10A, 10C, and WWV/JJY (15 MHz) bands.

The oscillators are controlled by Q₂₉₀₈ (2SC945) and Q₂₉₀₉ (2SA733) in accordance with the band in use. The output from the balanced mixer is fed through amplifiers Q₂₉₀₄ and Q₂₉₀₅ (both 2SC785) to the counter gate Q₂₉₁₃ (SN74LS00N).

The MHz display is programmed by the diode matrix Q₂₉₁₀ (MSL980Y7) and Q₂₉₁₁ (MSL980Y4). The output from Q₂₉₁₀ and Q₂₉₁₁ is

fed to the up/down counter Q₂₉₂₁ and Q₂₉₂₀ (both F40192); the output from the up/down counter is fed to drivers Q₂₉₂₃ and Q₂₉₂₂ (both MSM561) and then to the display LED's DS₃₀₀₁ and DS₃₀₀₂ (HP5082 - 7740).

The crystal oscillator/divider Q₂₉₁₂ (MM5564) generates a 655.36 kHz clock signal and produces 5 Hz gate pulses which are fed to the counter gate Q₂₉₁₃.

The pulses which pass through the gate are fed to the decade counter Q₂₉₁₅ (SN74LS90N), which counts 10 Hz digits. The 10th pulse at pin 12 of Q₂₉₁₅ is fed to Q₂₉₁₈ (MM5501), which counts 100 Hz, 1 kHz, 10 kHz, and 100 kHz digits. The BCD output signal from Q₂₉₁₈ is fed through driver Q₂₉₁₇ (MSM561) to the display LED's DS₃₀₀₃ - DS₃₀₀₆ (HP-5082 - 7740).

Q₂₉₁₉ (MC1416P) works as a series of switches operated by a timing signal delivered by Q₂₉₁₈ to select the output of Q₂₉₁₇ which drives the display LED's in a sequence of 100 Hz, 1 kHz, 10 kHz, and 100 kHz.

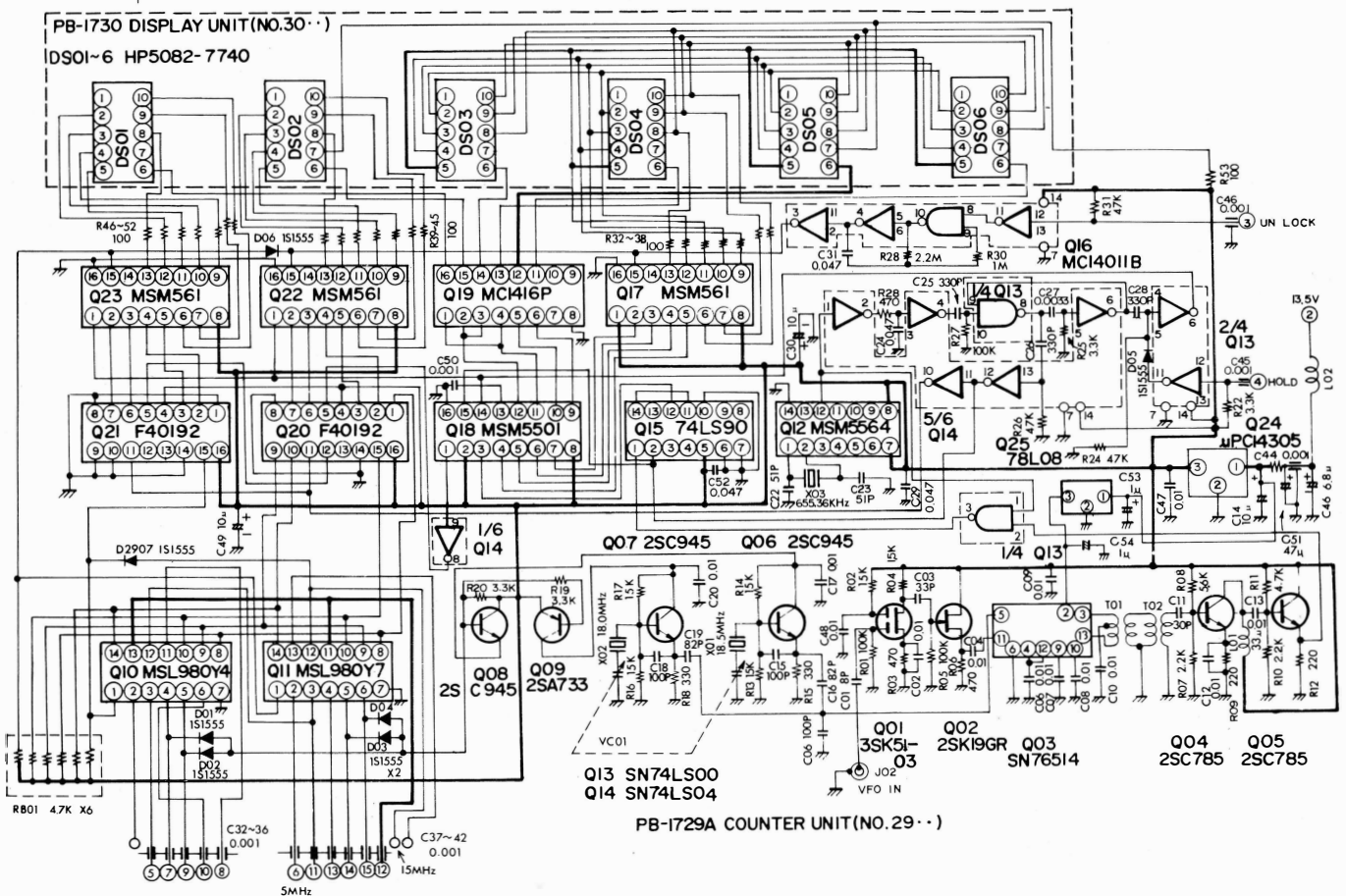

is amplified by Q₂₈₀₅ and Q₂₈₀₆ (both **JF-1033B**) and Q₂₈₀₇ (**2SC372Y**), and fed through a diode switch to the PLL UNIT (replacing the VFO signal).

Q₂₈₁₃ (**SN74LS00N**) and Q₂₈₁₄ (**SN74LS04N**) generate timing pulses to set or reset the counter.

The 200 Hz signal delivered from Q₂₈₁₁ is amplified by Q₂₈₀₈ (**MPSA13**) and rectified by D₂₈₀₄ and D₂₈₀₅ (both **1S188FM**) to produce a minus voltage to be used for operational amplifier Q₂₈₂₀.

POWER SUPPLY

The power supply is designed to operate from either 100/110/117/200/220/234 Volts AC 50/60 Hz (all models) or 13.5 Volts DC with the DC-DC converter unit (built-in on the FT-901DM, optional on other models). Insertion of the appropriate power plug into the rear panel receptacle makes the necessary connections for operation from either AC or DC power sources.

When the transceiver is operated from a 13.5 Volt DC power source, transistors Q₃₂₀₁ and Q₃₂₀₂ (both **T20A6**) function as a low frequency oscillator to provide AC voltage at approximately 80 Hz to the power transformer. All of the tube heaters receive their power through the HEATER switch on the front panel. With the HEATER switch in the OFF position, voltage is still supplied to the receiver section, thus allowing continuous reception with reduced power consumption. The heaters of the two 6146B are connected in series to operate at 12 Volts DC.

(1) Low voltage supply

AC 11.5 Volt power delivered from the secondary winding of the transformer is rectified by D₁₀₀₁ and D₁₀₀₂ (**V06B**) in the RECTIFIER A UNIT (**PB-1708**) to provide the transistor supply voltage. The rectified DC voltage is supplied through pin 8 and pin 1 of the AC plug to pin 1 of the power receptacle which is connected to the DC power supply line. In the DC mode, the DC voltage from the power cord is directly supplied to pin 1 of the power receptacle. The DC voltage is filtered through CH₁₀₀₁, C₁₀₀₁, and C₁₀₀₂, and fed to the voltage stabilizer Q₂ (**uPC14308**) (8V) and Q₃ (**μPC14312**) (+12V); 13.5 Volt power is also

supplied to the counter unit and accessory socket on the rear panel.

The stabilized 8 Volt supply from Q₂ is used for the VCO, XTAL and IF UNITS, and the stabilized 12 Volt supply is used for the FM, VOX, and AF UNITS, and other circuits as well. The 12 Volt supply is further stabilized by Q₁ (**uPC14308**) to be supplied to the AF and IF UNITS. A further portion of the 8 Volt supply from Q₂ is stabilized at 6 Volts by Q₁₈₀₁ (**TA7089M**) to be supplied to the VFO UNIT.

Independent voltage stabilizers are located in the MEMORY, COUNTER, AF, FM, and PLL UNITS.

(2) High voltage supply

The power amplifier plate voltage of +800 Volts DC is supplied from the bridge-controlled doubler RECTIFIER UNIT B consisting of D₁₄₀₁ - D₁₄₁₄ (**10D10**) and C₁₅₀₁ and C₁₅₀₂ in PB-1712.

AC 190 Volts is rectified by D₁₈₀₂ (**10D10**) in RECTIFIER UNIT C to obtain 210 Volts for the screen grid supply of the power amplifier tubes. The screen grid voltage is reduced to 180 Volts for the FM, AM, and FSK modes.

The plate supply for the driver tube is obtained by rectifying 250 Volt AC by D₁₈₀₁ (**10D10**). The DC voltage obtained from the RECTIFIER C UNIT is dropped to 160 Volts by a resistor for the driver screen grid.

120 Volt AC from the transformer secondary winding is rectified by D₁₀₀₄ (**10D10**) in the RECTIFIER A UNIT (**PB-1708**) to obtain -140 Volts for the grid bias voltage for the driver and final amplifier tubes.

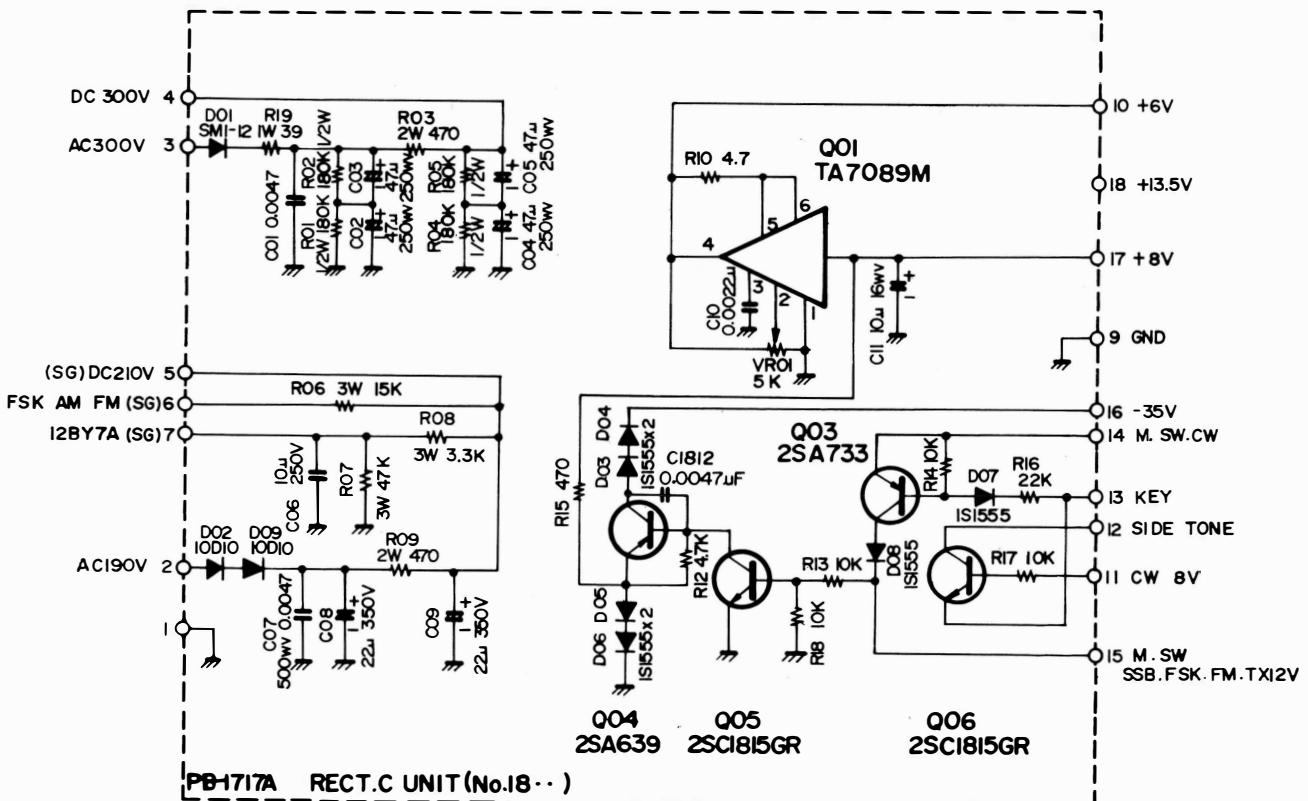
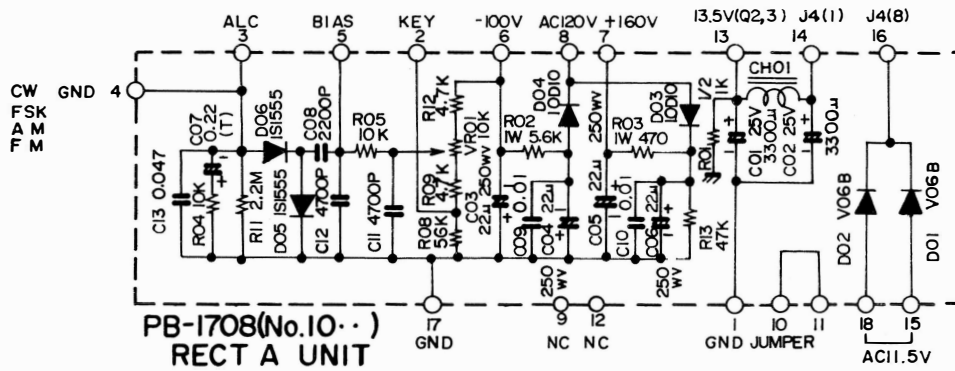
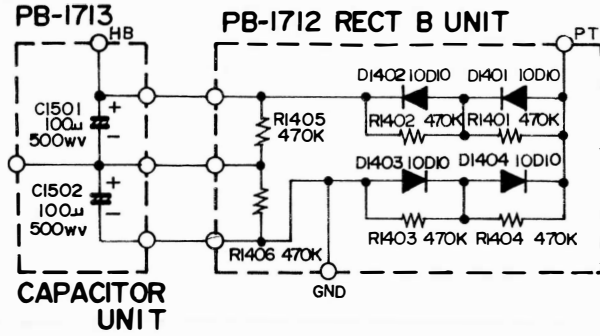

AM/CW FILTER INSTALLATION

Remove the top cover. Locate and remove PB-1716 (FILTER UNIT). Referring to Fig. 1, locate jumpers A and B on the printed board. If the AM filter is to be installed, the jumper marked A must be installed, and for CW filter installation the jumper marked B must be removed.

Referring to Figs. 1 and 2, install the desired filter in the appropriate holes. Make the fastening nuts snug (CW filter only), and solder the pins of the filter to the printed board.

Re-install PB-1716 in the chassis socket, and replace the cover of the transceiver.

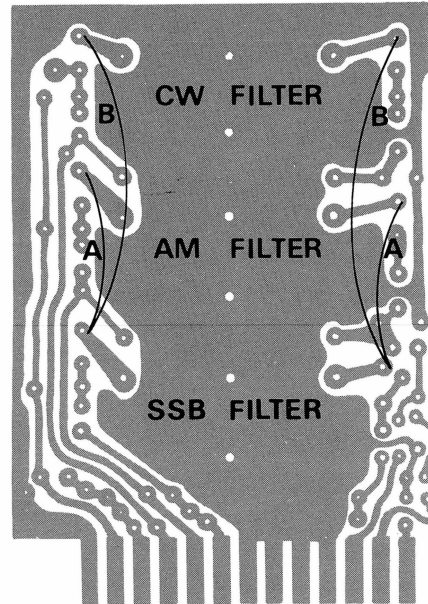

Figure 1

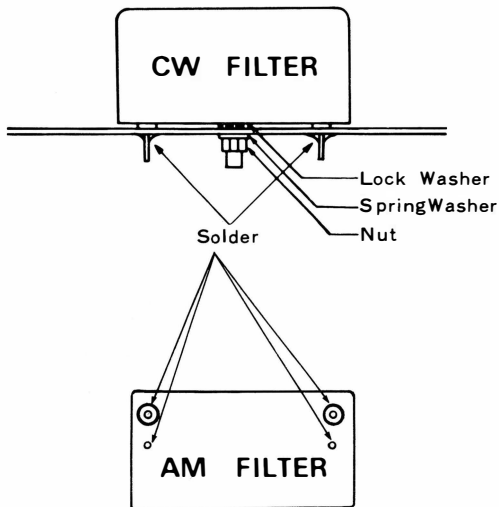
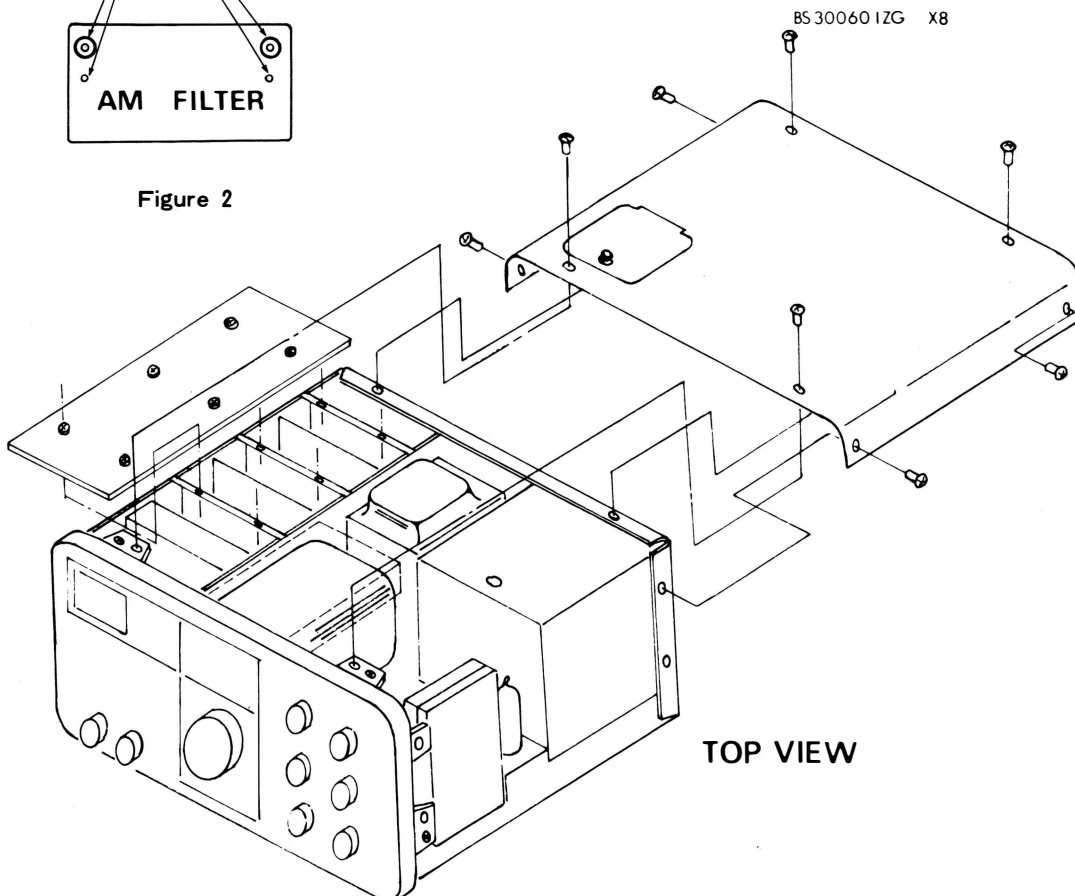

Figure 2



TOP VIEW

KEYER/MEMORY UNIT INSTALLATION

Remove the small cover from the bottom of the transceiver as shown in Fig. 1.

Install the MEMORY UNIT using the mounting screws supplied. Connect the 6-pin connector to the socket on the main chassis as shown.

Mount the KEYER UNIT as shown in Fig. 2, and connect the cable to the KEYER UNIT as shown in the drawing.

The completed installation may be viewed in Fig. 3.

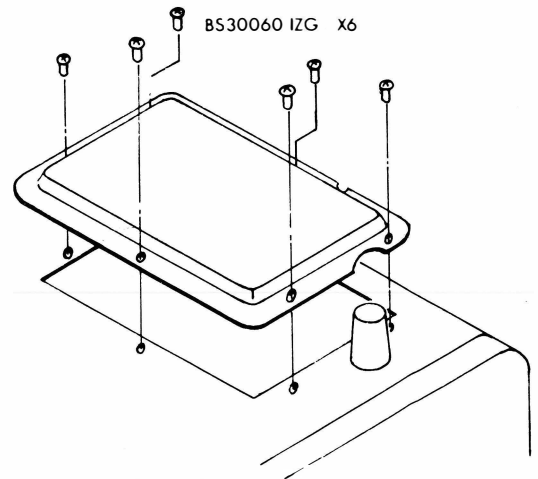
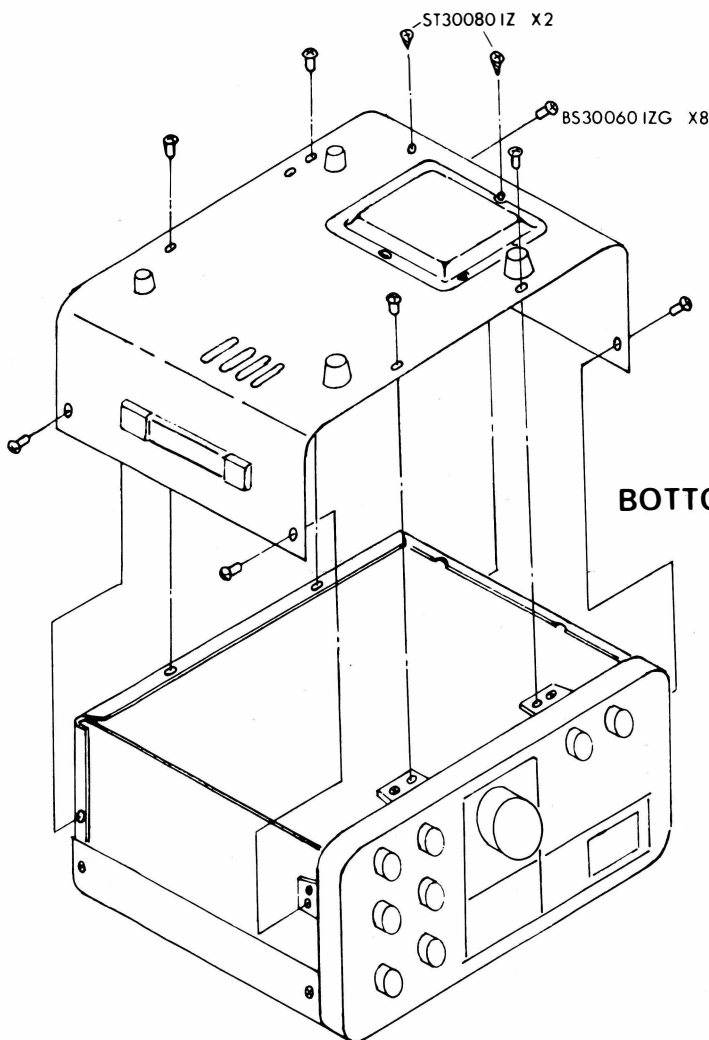

Figure 1



BOTTOM VIEW

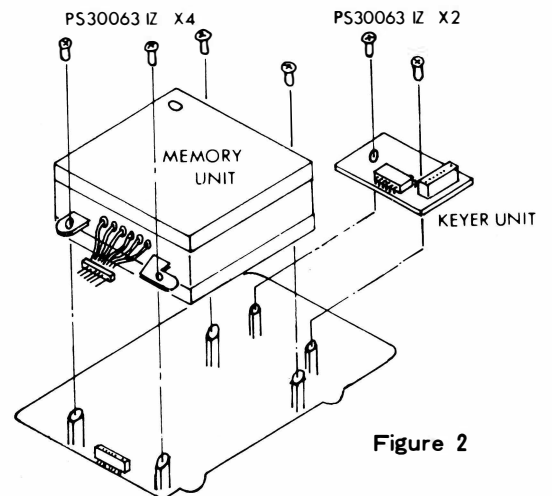

Figure 2

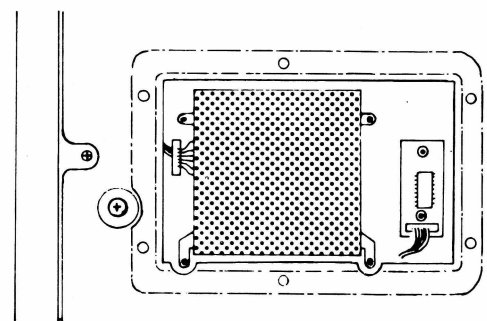
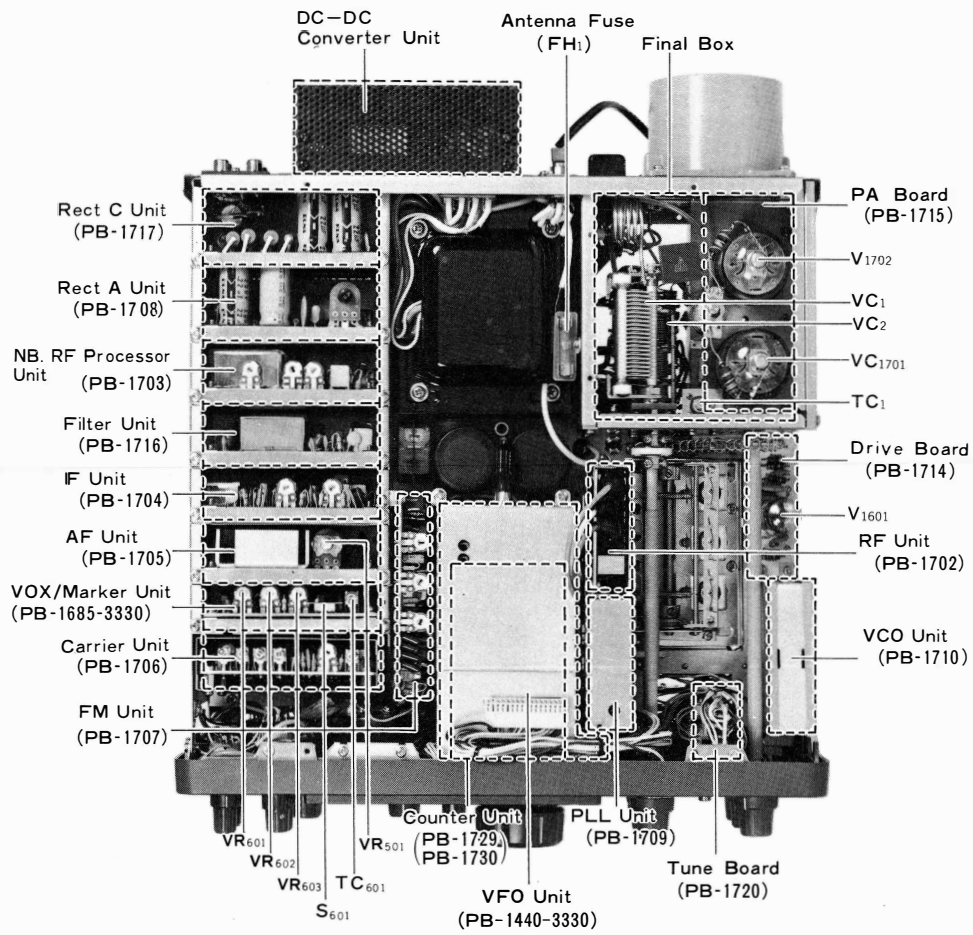
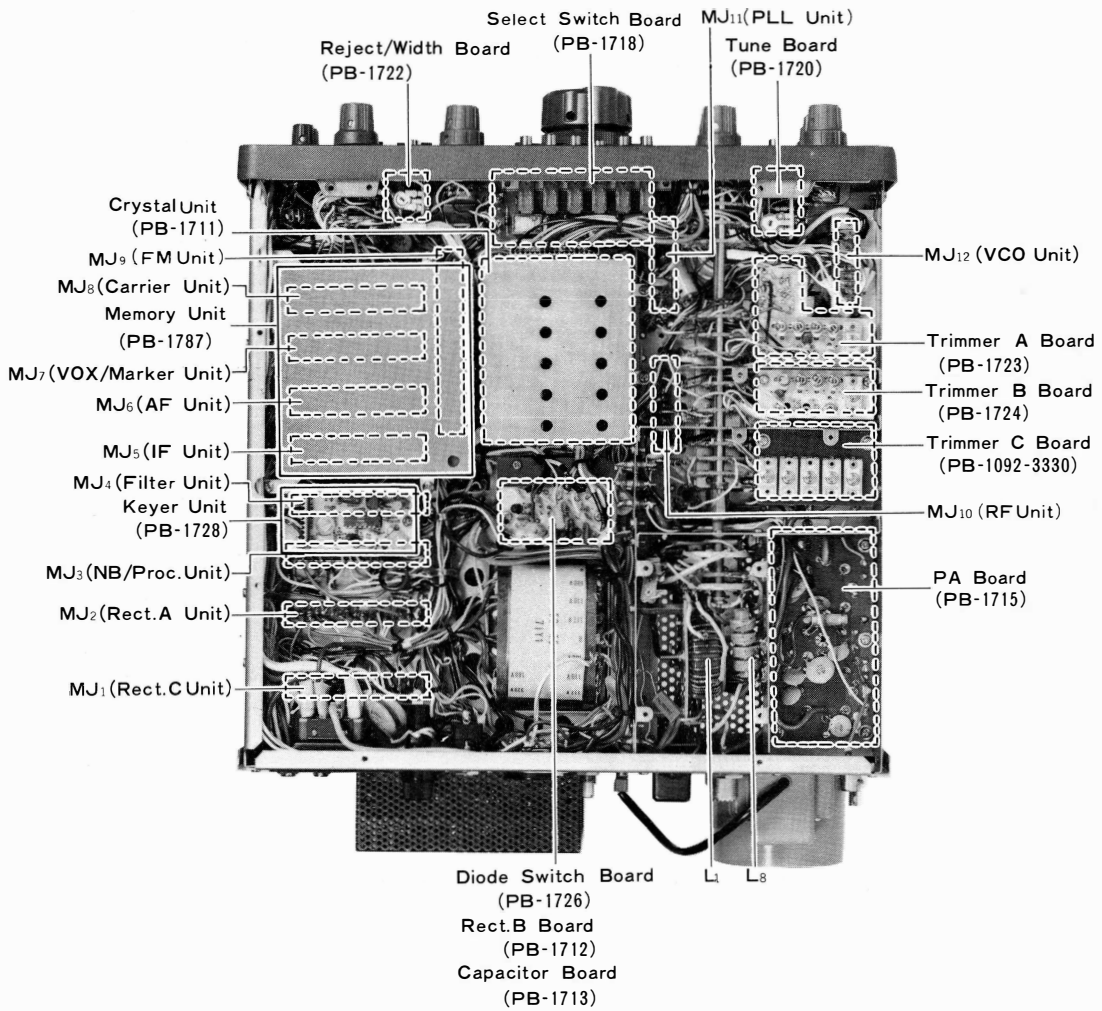

Figure 3



Top View



Bottom View

MAINTENANCE AND ALIGNMENT

WARNING

DANGEROUS VOLTAGES ARE PRESENT WITHIN THIS TRANSCEIVER. USE EXTREME CAUTION WHEN WORKING ON THE TRANSCEIVER WITH THE COVERS REMOVED. DISCHARGE ALL CAPACITORS BY SHORTING THEM TO GROUND WITH AN INSULATED SCREWDRIVER AFTER POWER HAS BEEN REMOVED, AND OBSERVE OTHER NORMAL SAFETY PRECAUTIONS.

CAUTION

Never operate this transceiver in the transmit mode without a matched antenna or dummy load connected to the antenna receptacle on the rear panel. It is possible to damage the final amplifier tubes and the pi network components if the transceiver is operated without the proper load termination.

GENERAL

This transceiver has been carefully aligned and tested at the factory and, with normal usage, should not require other than the usual attention given to electronic equipment. Service or realignment of a major component may require subsequent realignment; under no circumstances, though, should realignment be attempted unless the operation of the transceiver is fully understood, the malfunction has been carefully analyzed, and the fault has definitely been traced to misalignment. Service work should only be performed by experienced personnel using the proper test equipment.

EQUIPMENT REQUIRED

- (1) RF Signal Generator: Hewlett-Packard Model 606A or equivalent, with one volt output at 50 Ohms, and frequency coverage to 30 MHz.
- (2) Vacuum Tube Voltmeter (VTVM): Hewlett-Packard Model 410B or equivalent, with an RF probe good to 40 MHz.
- (3) Dummy Load: Yaesu model YP-150 or equivalent, with 50 Ohm non-reactive load impedance rated to 150 watts average power.
- (4) AF Signal Generator: Hewlett-Packard Model 200AB or equivalent.
- (5) A general coverage receiver covering the frequency range from 3 to 30 MHz with a 100 kHz calibrator.
- (6) A frequency counter, Yaesu Model YC-500 or equivalent, with resolution to .01 kHz and frequency coverage to 30 MHz.

1. S-METER SENSITIVITY ADJUSTMENT

Place the transceiver in the receive mode and connect a signal generator to the antenna terminal of the transceiver. Set the signal generator to 14200 kHz with an output of 6 dB. Tune the transceiver to 14200 kHz for a maximum reading on the S-meter. The S-meter should just start to rise with a 6 dB input. If no deflection is observed, adjust VR₄₀₂ to obtain a slight meter deflection. Apply 100 dB input to the antenna terminal; the S-meter should read S9 + 60 dB. If not, adjust VR₄₀₁. VR₄₀₁ and VR₄₀₂ are located on PB-1704.

When the transceiver is tuned to 14200 kHz, the 100 kHz calibrator signal will indicate approximately S9 + 10 dB when MARK switch is activated.

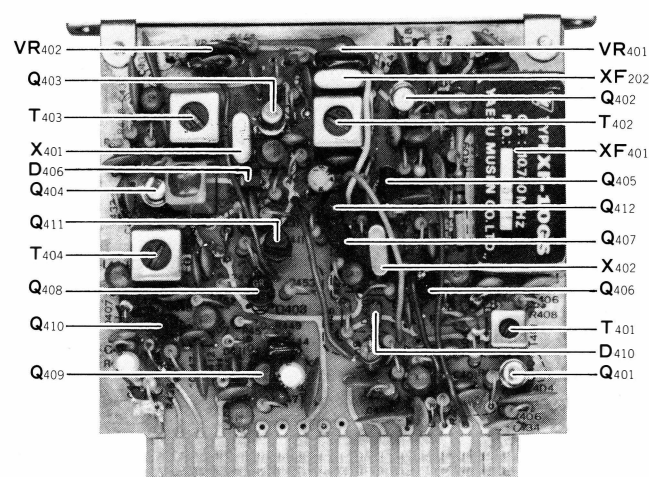

IF unit (PB-1704)

2. VOX ADJUSTMENT

Tune in a signal and adjust the AF GAIN control for a normal listening level. With the microphone positioned near the speaker, increase the VOX GAIN control on the front panel until the speaker output causes the VOX relay to switch to the transmit mode. Set the ANTITRIP control VR₆₀₁ on PB-1685 to the point that will just prevent the speaker output from tripping the VOX relay. Speak into the microphone in a normal voice to see if one's voice will activate the VOX relay. If not, VR₆₀₁ may be advanced too far.

Adjust the DELAY control VR₆₀₂ for the desired release delay. Clockwise rotation of VR₆₀₂ will increase the delay time. For CW semi-break-in operation, VR₆₀₂ should likewise be adjusted to suit the operator's preferences. For CW operation with a footswitch for relay actuation, the VOX GAIN control may be rotated fully counterclockwise (but not to the click-stop, which is the MOX position) to disable the VOX system.

3. CW SIDETONE LEVEL

Adjustment of the CW sidetone level may be made by adjustment of potentiometer VR₆₀₃, located on PB-1685, while the transceiver is being keyed.

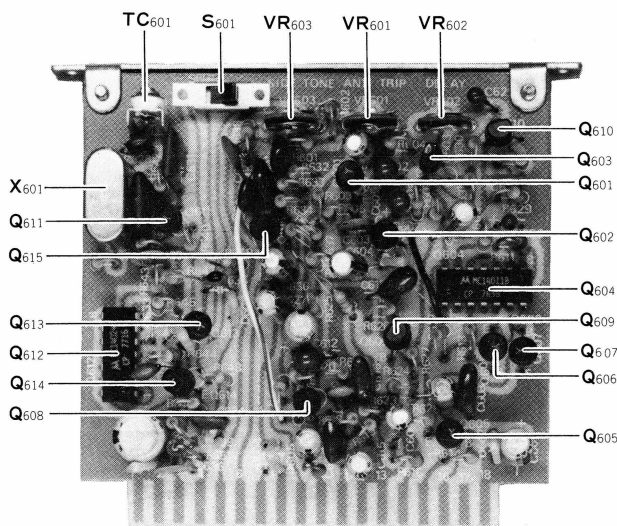

VOX/Marker unit PB-1846 (PB-1685-3330)

4. CARRIER BALANCE

The transceiver should be allowed to reach normal operating temperature before making carrier balance adjustments.

Tune up the transceiver for SSB operation using a

matched antenna or dummy load. Turn the MIC GAIN control fully counterclockwise to remove all audio input from the modulator stage.

With the MODE switch set to either LSB or USB, turn the VOX GAIN control to MOX and adjust the carrier balance controls VR₇₀₁ and TC₇₀₅ on PB-1706 for a minimum meter reading with the METER switch in the PO position.

A more precise balance may be obtained by tuning a receiver which has an S meter to the transmitted frequency. Adjust VR₇₀₁ and TC₇₀₅ for a minimum S meter reading on the remote receiver while switching the MODE switch back and forth between the two SSB positions; this will help ensure good carrier suppression on both LSB and USB.

5. AMGC (Automatic Mic Gain Control)

The hold time of the AMGC system is adjusted by VR₇₀₂ on PB-1706; clockwise rotation of VR₇₀₂ will provide a longer hold time.

6. CARRIER FREQUENCY ADJUSTMENT

Tune up the transmitter on 20 meters in the USB mode, using a dummy load. Apply a 1 kHz audio signal to the microphone input and adjust the audio generator output for 30 watts output from the transmitter as measured by the dummy load wattmeter. Shift the audio generator output frequency to 300 Hz without changing its output level. Adjust TC₇₀₁ until the power output becomes 8 watts. Repeat this procedure for the LSB mode.

NOTE: Recheck the carrier balance after adjusting the carrier frequency.

Connect a frequency counter to pin 17 of the NB UNIT PB-1703. Transmit in the AM mode. Set TC₇₀₃ for a reading of 8988.295 kHz on the frequency counter.

Transmit on the FSK mode. Set TC₇₀₄ a reading of 8988.125 kHz on the frequency counter. Repeat this procedure for AM and then FSK until both frequencies are indicated correctly on the counter. Ground the inner conductor of the FSK jack on the rear panel and confirm that the frequency shifts to 8988.295 kHz.

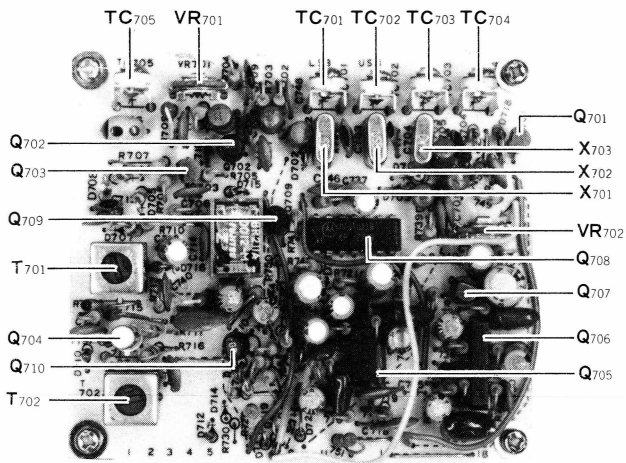

Carrier unit (PB-1706)

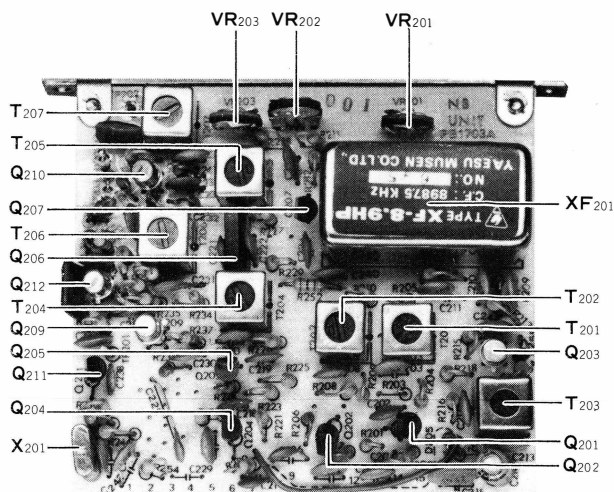

NB/PROC unit (PB-1703)

7. ALC LEVEL ADJUSTMENT

Set the METER switch to ALC, the MODE switch to USB or LSB, the MIC GAIN control counter-clockwise, and the VOX GAIN control to MOX. If the meter reading is not fully deflected to the right, adjustment of the ALC level control VR₂₀₁ on PB-1703 will be required. Adjust VR₂₀₁ for a reading of 350 (full scale) and return the VOX GAIN control to PTT.

8. RF SPEECH PROCESSOR ADJUSTMENT

Tune up the transceiver on USB at 14.2 MHz. Set VR₂₀₂ and the PROC LEVEL controls to the center of their range. Apply a 1 kHz audio signal to the microphone input and adjust its level to the point where power output levels off after reaching its maximum value; do not advance the input level past the saturation point. Adjust VR₂₀₃ so as to obtain the same power output when the RF Processor switch is in the ON and OFF positions.

9. IF PASSBAND TUNING ADJUSTMENT

Tune the receiver to 14.2 MHz in the USB mode and set the WIDTH control to the 12 o'clock position. Set the RF GAIN control fully clockwise.

Change the MODE switch from USB to LSB. The receiver background noise at the speaker should not change in pitch. If there is any difference, adjust VR₂₃₀₁ located adjacent to the MODE switch below the chassis until the noise is of the same pitch when switching between USB and LSB.

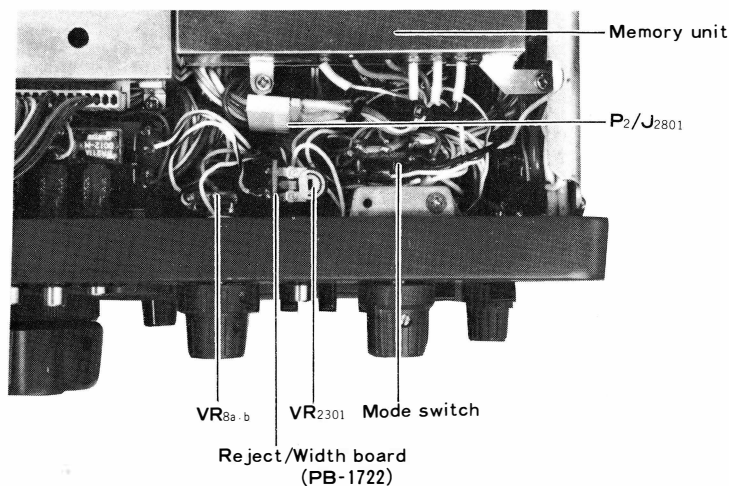

10. APF SELECTIVITY

The selectivity of the APF (Audio Peak Filter) can be adjusted by varying VR₅₀₁, located on PB-1705. Clockwise rotation of VR₅₀₁ will yield sharper selectivity of the filter.

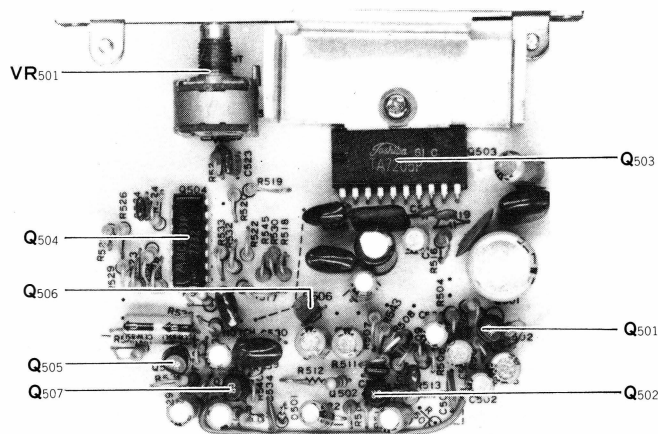

AF unit (PB-1705)

11. KEYSER ADJUSTMENT

VR₂₇₀₂ controls the dot-to-space ratio for the built-in electronic keyer; this is normally set to 1:1 at the factory. VR₂₇₀₁ adjusts the symmetry between dots and dashes. Once VR₂₇₀₁ is set, this setting is correct for all keying speeds. Adjustment of VR₂₇₀₂ will make both dots and dashes change uniformly with respect to the space. Both of these controls are located on PB-1728.

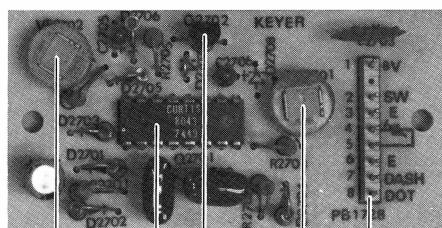

VR₂₇₀₂ Q₂₇₀₁ VR₂₇₀₁ J₂₇₀₁

Keyer unit (PB-1728)

12. CLARIFIER ADJUSTMENT

With the transceiver in the receive mode, push the RX CLARIFIER button and set the CLARIFIER control to 0. Tune in the marker signal on any band and then switch the RX CLARIFIER button OFF. If the frequency changes at all, adjust potentiometer VR₂₁₀₁, which is located inside the cabinet near the CLARIFIER control potentiometer.

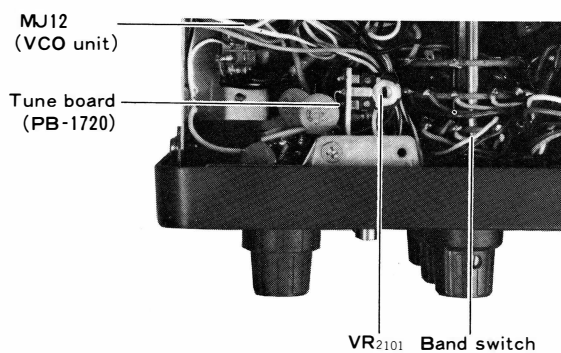

VR₂₁₀₁ Band switch

13. VOLTAGE REGULATOR ADJUSTMENT

Connect a VTVM DC probe between pin 10 of MJ₁ (PB-1717) and ground. Adjust 6V SET potentiometer VR₁₈₀₁ for exactly 6 Volts as indicated on the VTVM.

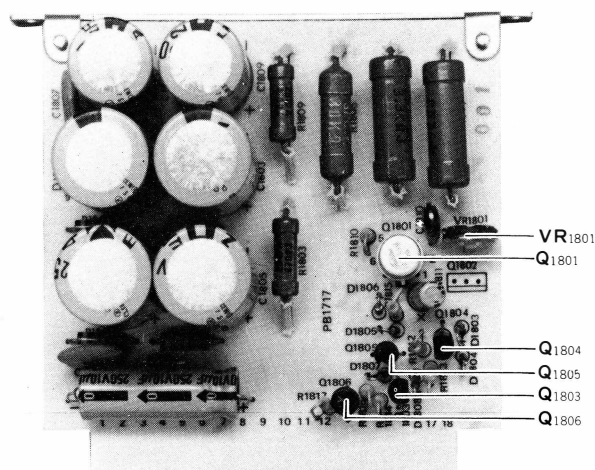

Rectifier C unit (PB-1717)

14. BIAS ADJUSTMENT

The final amplifier bias must be checked to ensure linearity and normal operating plate dissipation for the final amplifier tubes. Adjust the BIAS control VR₁₀₀₁ on PB-1708 as follows: set the transceiver in the receive mode and allow the tubes to reach normal operating temperature. Set the MODE switch to USB, the METER switch to IC, and the VOX GAIN control to MOX, so as to activate the transmitter. The meter will then indicate cathode current for the PA tubes. The idling cathode current is 50 mA if the bias is correct (25 mA for the SD model). If the idling cathode current is other than 50 mA, adjust the BIAS control VR₁₀₀₁ for the correct value.

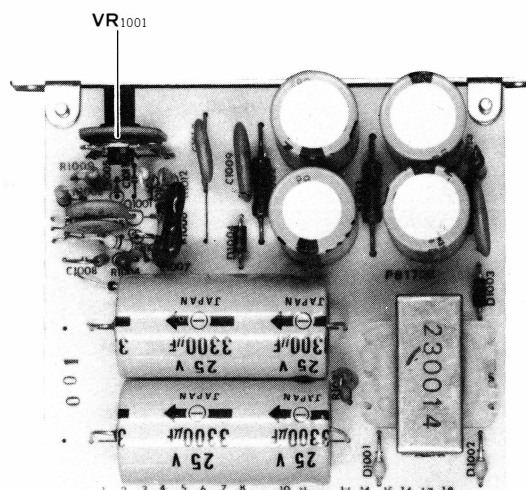

Rectifier A unit (PB-1708)

15. POWER OUTPUT METER ADJUSTMENT

VR₇, located on the transceiver rear panel adjacent to the RCV ANT jack, provides adjustment for the relative power output indication on the front panel meter.

With the transceiver tuned at full power into a 50 Ohm dummy load, VR₇ should be adjusted to indicate 1/2 to 2/3 full scale meter deflection, with the METER switch in the PO position.

It should be noted that the PO meter indicates relative power output, and it is not the basis for determining actual power output.

VR₇ has been preset at the factory to read 1/2 to 2/3 full scale into a 50 Ohm dummy load. The operator should not indiscriminately adjust VR₇ while using an unknown load or antenna of possibly high VSWR.

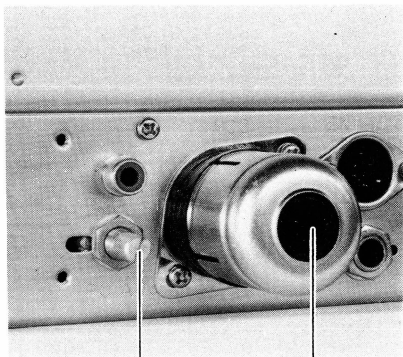

PO Meter Adjust (VR₇) Accessory Plug

16. FINAL AMPLIFIER NEUTRALIZATION

When replacing the final amplifier tubes, it may be necessary to reset the bias to give the correct idling current, and to check neutralization. Using the procedure outlined below will guarantee maximum output and long tube life.

CAUTION

HIGH VOLTAGES ARE PRESENT ON THE UNDERSIDE OF THE CHASSIS AND INSIDE THE FINAL AMPLIFIER COMPARTMENT. USE GREAT CARE WHILE MAKING ADJUSTMENTS IN AREAS OF EXPOSED WIRING.

- (1) Connect a dummy load to the antenna receptacle, and set the METER switch to IC.

- (2) Locate TC₀₁, the neutralization variable capacitor shaft, on the inside wall of the final amplifier compartment.
- (3) Check the final amplifier idling current as described in part 7 of this section of the manual (BIAS ADJUSTMENT).
- (4) Tune up the transceiver at 29 MHz, using either the 10B or 10C band, and adjust the carrier level so that it is 150 mA. in the TUNE condition.
- (5) Rotate the PLATE tuning control and observe the point of minimum current ("dip"). If the dip is not prominent, reduce the LOADING control slightly to get a better dip. As the PLATE control is rotated the meter should rise equally and smoothly on either side of the dip.
- (6) Determine which side of the dip rises abruptly. Set the PLATE control slightly to this side of the dip, keep the meter reading below 100 mA.
- (7) Using a nonmetallic tuning wand, rotate the neutralization capacitor shaft very slightly in the direction which reduces the current on the meter. Repeat steps 6 and 7 until the meter indicates a smooth and equal rise on either side of the dip.

NOTE: The final amplifier compartment cover must be in place to supply the RF shielding required during the neutralization procedure.

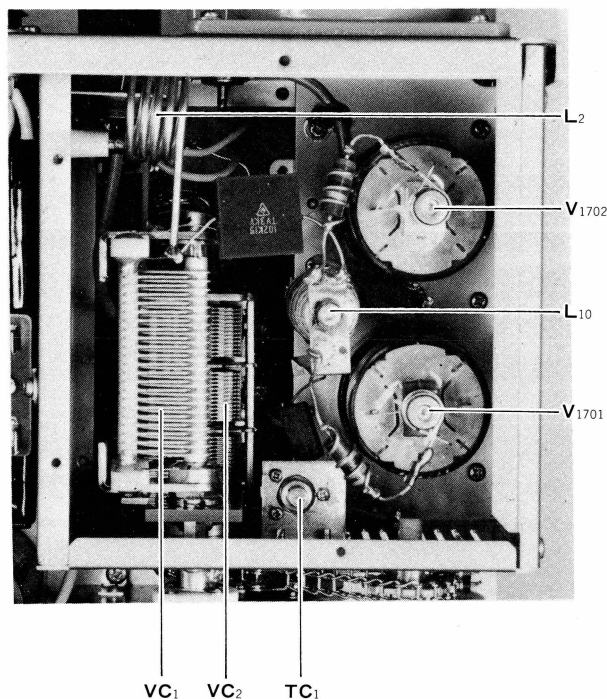

Final Amplifier Compartment

17. ALIGNMENT OF TRANSMITTER MIXER/DRIVER AND RECEIVER FRONT END STAGE

- (1) Connect a dummy load/wattmeter to the rear panel ANT jack.
- (2) Set the RF/AF gain controls fully clockwise, set the MODE switch to FSK, and set TC₂₅₀₆ to the 1/3 capacitance setting, as shown in Fig. 1 .
- (3) Set the BAND switch to 10D, set the main tuning dial for a reading of 30.000 MHz, and set the PRESELECT control to the upper end of the 10 meter band (fully clockwise). Set the LOAD control to 3, and dip the PLATE CONTROL while tuning.
- (4) Set the CARR control to the 12 o'clock position. Set the VOX GAIN control to MOX (for not more than 10 seconds), and carefully adjust T₂ and T₃ for maximum IC reading on the meter. Be sure that the bonding agent has been removed before you adjust the cores.
- (5) While receiving, set the MARKER switch ON, and tune to the calibrator signal. Adjust T₁ for maximum S-meter deflection.
- (6) Now set the BAND switch to 10A, set the VFO for a display frequency of 28.000 MHz, and peak the PRESELECT control for maximum PO while tuning. Dip the PLATE control for minimum IC indication. Now set the VOX GAIN switch to MOX, and adjust TC₂₅₀₆ maximum IC indication on the meter (FSK mode, still).
- (7) Set the MARKER switch ON, and tune to the calibrator signal. Peak TC₂₄₀₆ for maximum S-meter deflection.
- (8) As there may be some interaction of adjustments, please repeat steps (3) through (7).
- (9) Adjust the final amplifier neutralization, as described on page 45.
- (10) Again repeat steps (3) through (8).
- (11) Now you are ready to align the other bands. Set the BAND switch to 15, set the main tuning dial for a reading of 21.000 MHz, and set the PRESELECT control at 8.6 on its scale. Dip the PLATE control for minimum IC indication while tuning. Set the VOX GAIN control to MOX, and adjust TC₂₆₀₅ and TC₂₅₀₅ for maximum PO indication on the meter. On receive, tune in the MARKER signal, and adjust TC₂₄₀₅ for maximum S-meter deflection.
- (12) Set the BAND switch to 20, set the VFO for a frequency of 14.000 MHz, and set the PRESELECT control to 7.2 on its scale. Dip the PLATE control for minimum IC indication while tuning. Set the VOX GAIN control to MOX, and adjust TC₂₆₀₄ for maximum PO indication on the meter. On receive, tune in the MARKER signal, and adjust TC₂₄₀₄ for maximum S-meter deflection.
- (13) Set the BAND switch to 80, tune the main dial for a reading of 4.000 MHz, and set the PRESELECT control to 6 on its scale. Dip the PLATE control for minimum IC indication while tuning. Set the VOX GAIN control to MOX, and adjust L₉ and T₂₅₀₁ for maximum PO indication on the meter. On receive, tune in the MARKER signal, and adjust T₂₄₀₁ for maximum S-meter deflection.
- (14) Set the main tuning dial for a reading of 3.500 MHz, and set the PRESELECT control to 2 on its scale. Dip the PLATE control for minimum IC indication while tuning. Set the VOX GAIN control to MOX, and adjust TC₂₆₀₂ and TC₂₅₀₂ for maximum PO indication on the meter. On receive, tune in the MARKER signal, and adjust TC₂₄₀₂ for maximum S-meter deflection.
- (15) Because of possible interaction of adjustments, please repeat steps (13) and (14).
- (16) Set the BAND switch to 40, tune the main dial for a reading of 7.200 MHz, and set the PRESELECT control to 6.5 on its scale. Dip the PLATE control for a minimum IC reading while tuning. Set the VOX GAIN control to MOX, and adjust TC₂₆₀₃ and TC₂₅₀₃ for maximum PO indication on the meter. On receive, tune in the MARKER signal, and adjust TC₂₄₀₃ for maximum S-meter deflection.

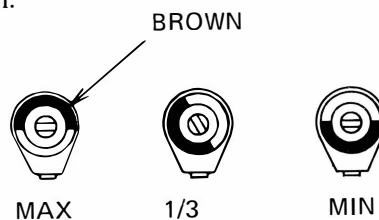

Fig. 1

ADVICE ON TROUBLESHOOTING THE DRIVER/FINAL STAGES

Three tubes are used in the FT-901DM: a 12BY7A and two 6146B's, run in parallel in the final.

Because not all service personnel are as familiar with tubes as they are with semiconductors, we would begin by cautioning you that tubes are voltage devices. To produce power in useful amounts, they require voltages well in excess of that needed for solid state devices. Take care, lest you quickly develop "serviceman's elbow," a malady well known to old timers. It occurs when your arm jerks back from the +800 volts right into some immovable object. Accompanied by a few colorful phrases, it is not an experience one knowingly encourages, though it is seldom fatal.

If you should come into contact with the high voltage, it is best to take a break from servicing. Alert your colleagues to what happened, and seek medical attention should any signs of shock (trauma) develop. Trauma following contact with high voltage is sometimes more dangerous than the high voltage itself. **IT CAN BE FATAL!**

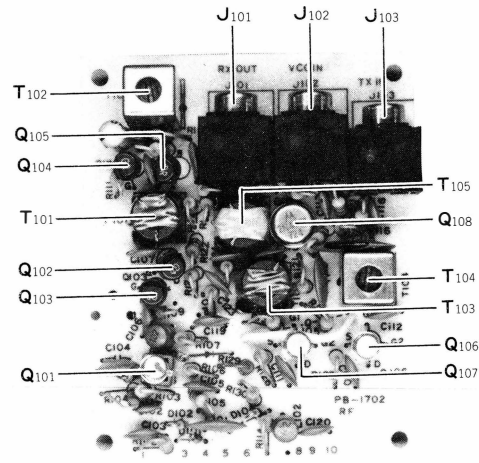

RF unit (PB-1702)

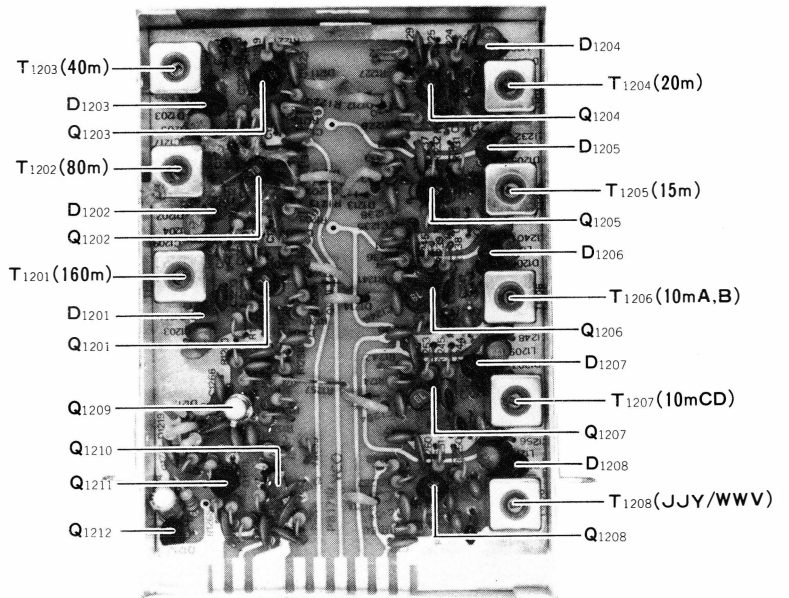

VCO unit (PB-1710)

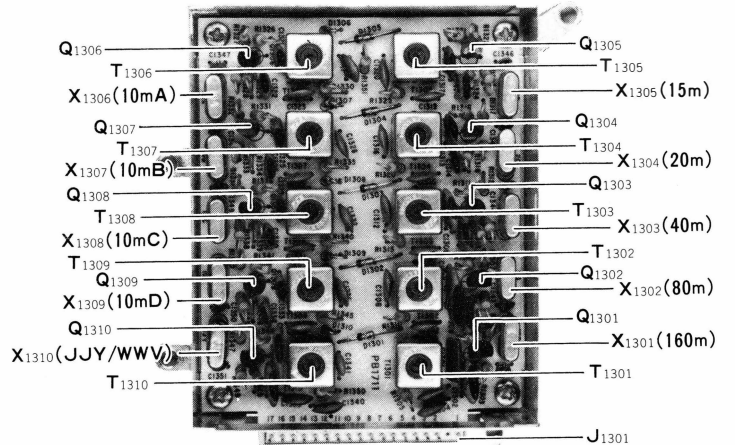
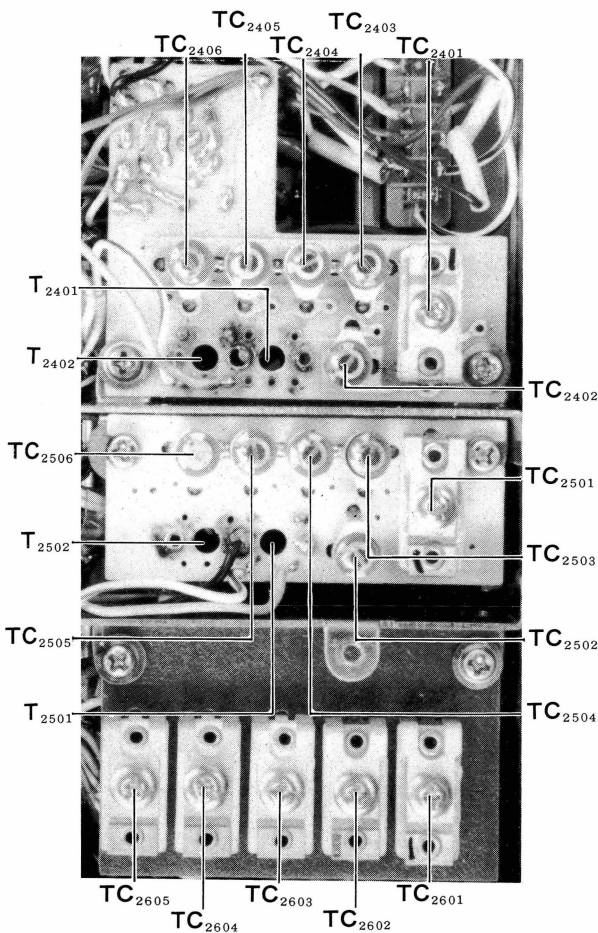

Crystal unit (PB-1711)

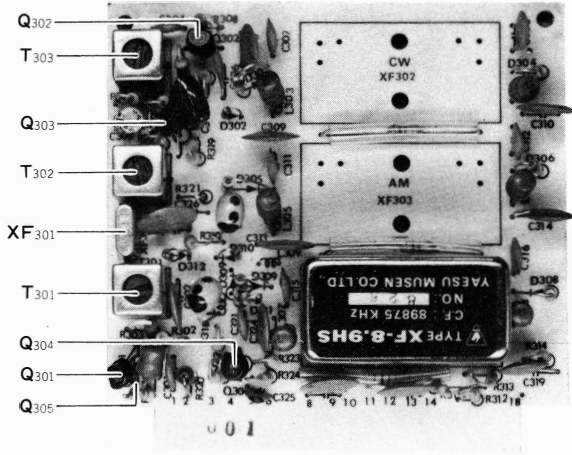

Filter unit (PB-1716)

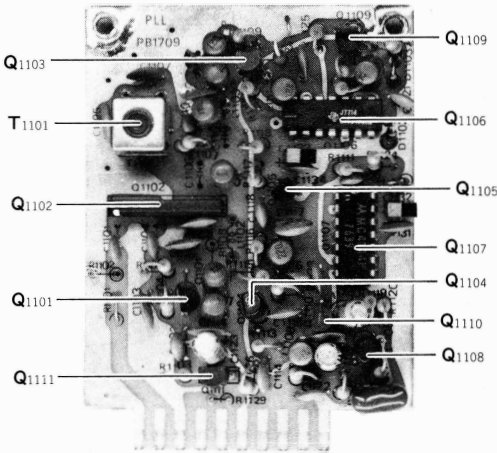
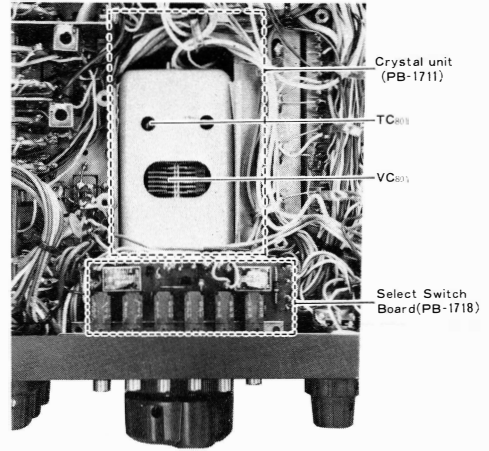

PLL unit (PB-1709)

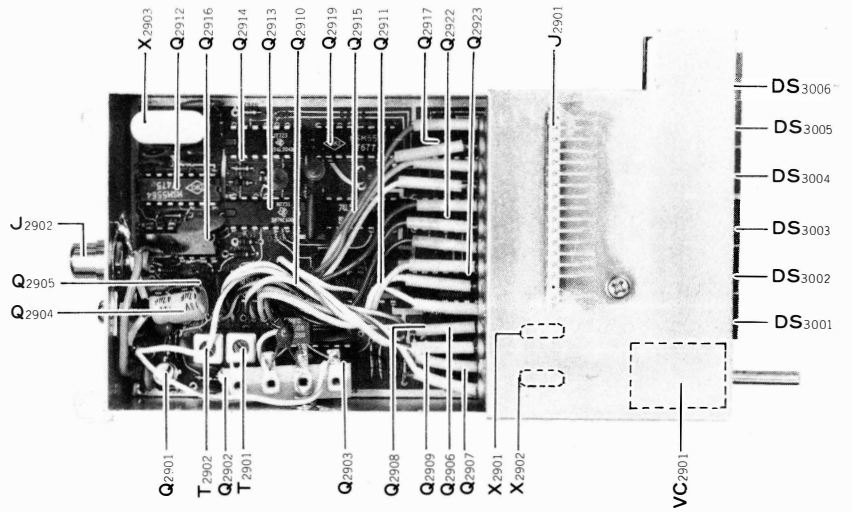

Counter/Display unit (PB-1729, PB-1730)

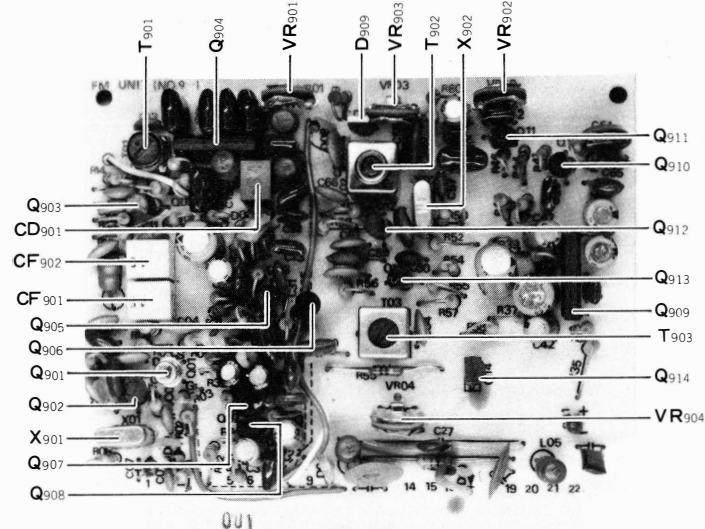

FM unit (PB-1707)

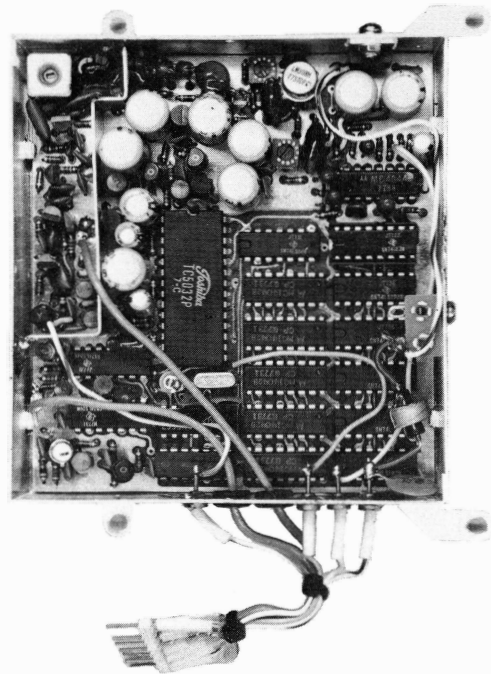

Memory unit (PB-1787)



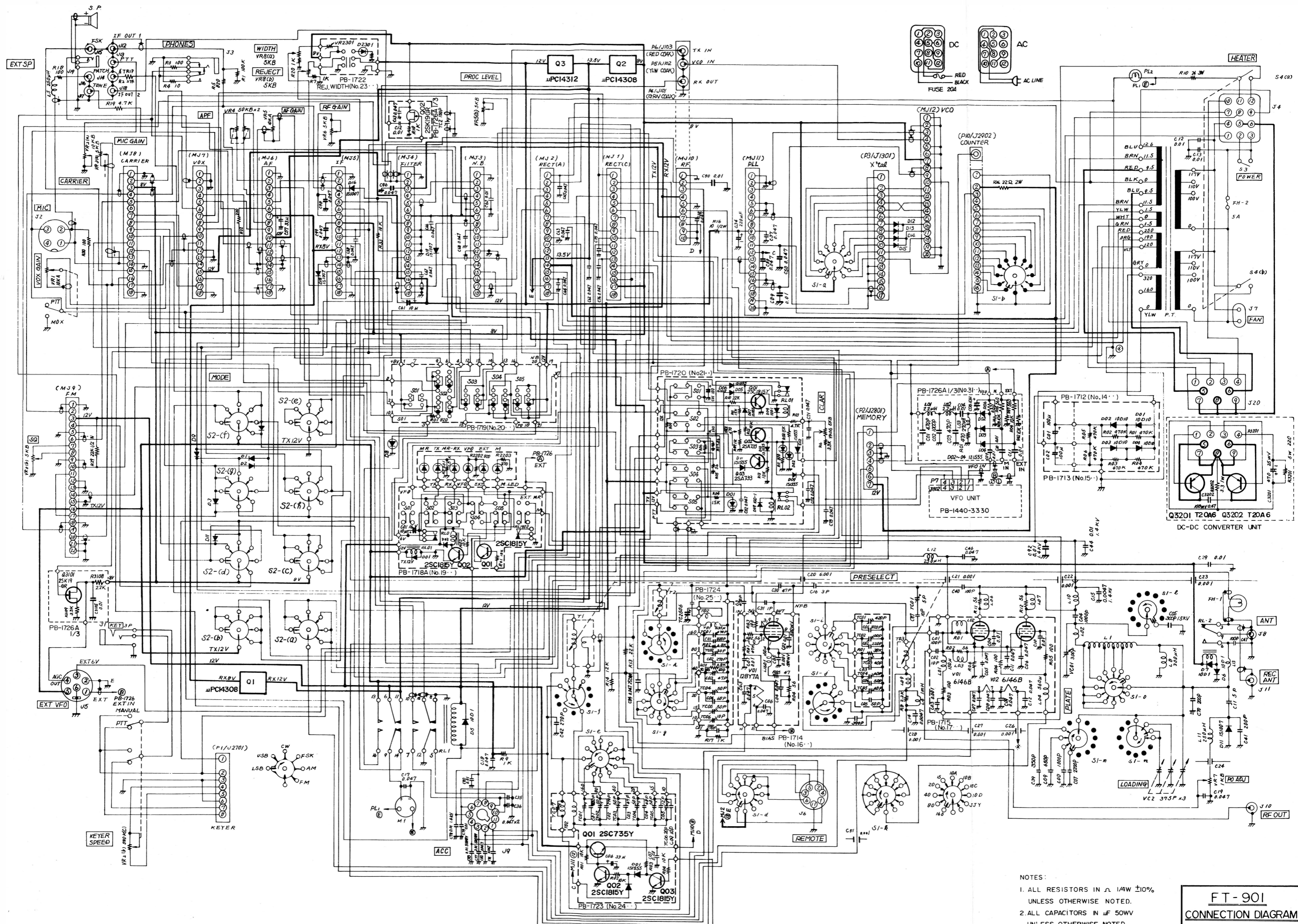

- NOTES:
1. ALL RESISTORS IN Ω 1/4W $\pm 10\%$ UNLESS OTHERWISE NOTED.
 2. ALL CAPACITORS IN μF 50WV UNLESS OTHERWISE NOTED.

FT - 901
CONNECTION DIAGRAM