

MATTEL ELECTRONICS®

SERVICE MANUAL



INTELLIVISION® II

MODEL 5872

MATTEL ELECTRONICS

5150 Rosecrans Avenue
Hawthorne, California 90250

TABLE OF CONTENTS

1. SPECIFICATIONS	Page 1
2. OPERATING INSTRUCTIONS	Page 2
3. SYSTEM DESCRIPTION AND OPERATION	Page 5
4. SYSTEM TESTING	Page 9
5. DISASSEMBLY PROCEDURE	Page 9
6. PRELIMINARY CHECKLIST	Page 10
7. TROUBLESHOOTING	Page 11
8. ADJUSTMENTS	Page 20
9. PARTS LIST	Page 21
10. SCHEMATIC DIAGRAM	Page 25

SPECIFICATIONS

MICROPROCESSOR (CPU) — General Instrument CP-1610 16-bit processor.

MEMORY — 7K internal ROM, RAM, and I/O structures, remaining 64K address space available for external programs.

CONTROLS — Two removable hand controllers: 12-button numeric keypad, four action buttons, 16-position directional movement disc.

SOUND — Programmable sound generator (PSG) capable of producing three simultaneous sound patterns.

COLOR REPRODUCTION — 16 different color hues:

Black	Gray
Blue	Cyan
Red	Orange
Tan	Brown
Dark Green	Magenta
Light Green	Light Blue
Yellow	Yellow-Green
White	Purple

VIDEO RESOLUTION — 192 vertical x 160 horizontal picture elements.

VOLTAGE REQUIREMENTS — 120VAC 60 Hz

DIMENSIONS: (WxDxH) — 10" x 6¾" x 3"

WEIGHT — Console Assembly with Packing Material and Accessories — 4.7 lb.
Console Assembly alone — 2.3 lb.

ACCESSORIES — Antenna Switch Box, Switch Box Cable (15 feet), Wall-Mounted Power Transformer, and Owner's Manual.

OPERATING INSTRUCTIONS

A. Connection to the color television receiver

1. Connect the twin lead from the antenna switchbox to the VHF antenna input of the television receiver. Figure 1 illustrates the proper connection when twin lead is used from antenna system; Figure 2 illustrates the proper connection when coaxial cable is used. If the TV receiver has only 75 ohm coaxial input, then a 300 to 75 ohm adaptor must be used.

2. Connect the RF cable from the RF output jack on the Master Component to the jack marked GAME on the antenna switch box. Place switch box to the GAME position.
3. Set the television receiver to channel 3 or 4, whichever is not used in your broadcast area. Place the RF channel select switch (located at the back of the Master Component) to correspond to the channel set on the television.

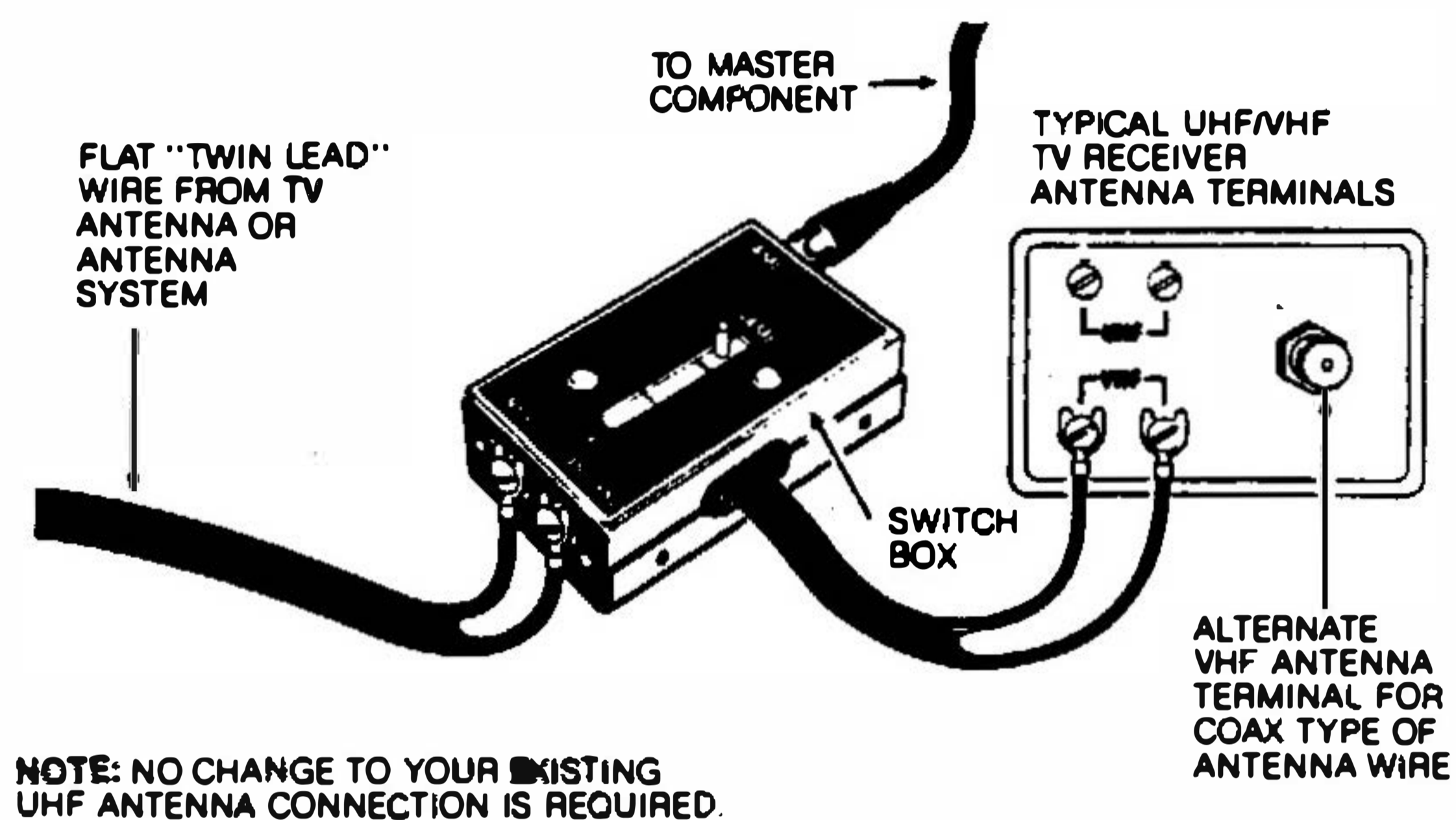

Figure 1

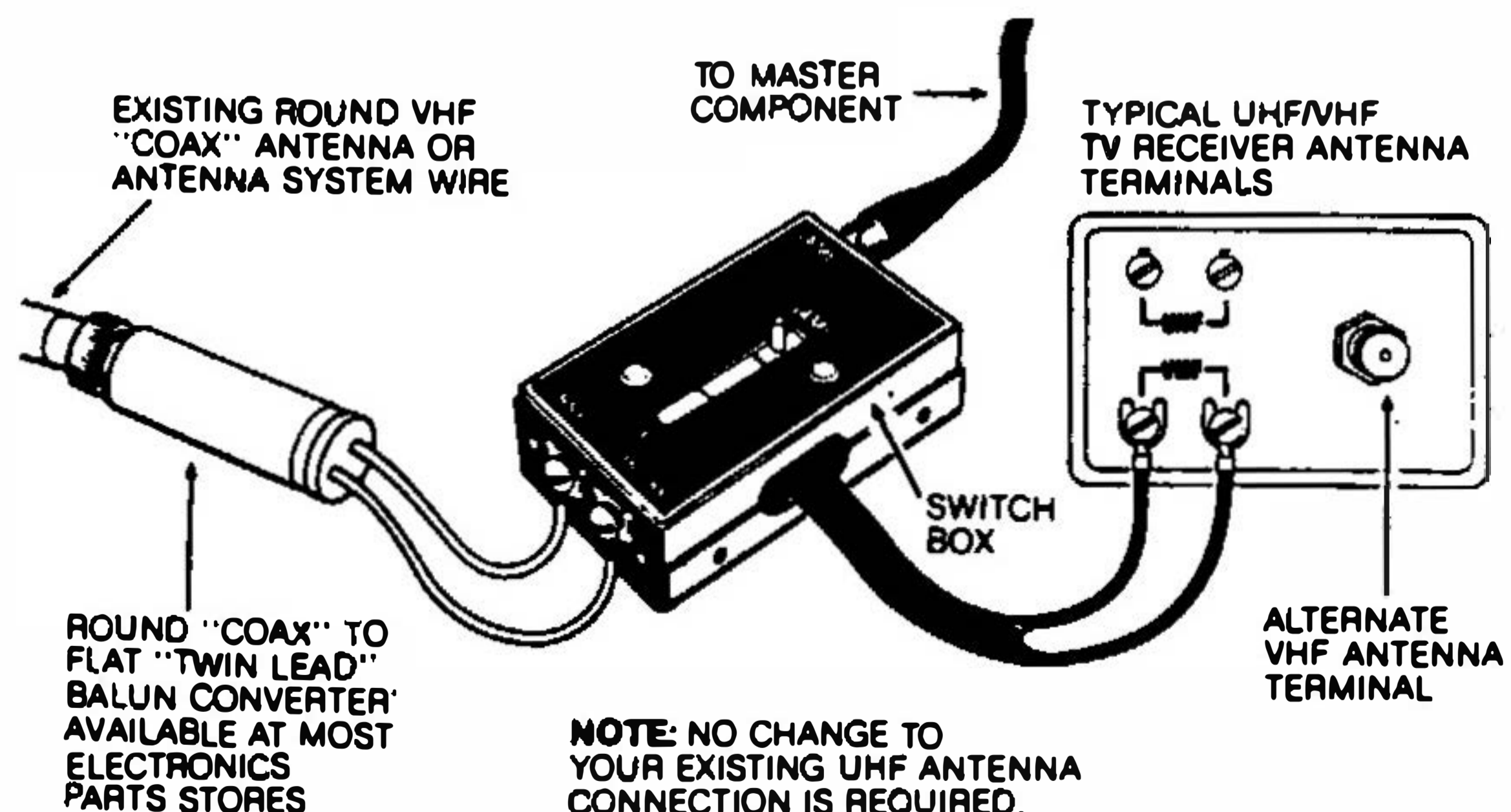

Figure 2

B. Power Connection

1. Plug the transformer unit into a 120 Volt 60 Hz wall outlet.
2. Insert the other end of the power cord into the rear-panel power socket.

C. Gameplay

1. Turn TV set ON.
2. Insert the game cartridge in the slot located on the right side of the Master Component (Figure 3).
3. Remove the Hand Controllers from their holder on the Master Component.
4. Depress the ON/OFF/RESET switch button to turn on the Master Component.
5. RESET: Tapping the ON/OFF/RESET button will cause the game being played to be reset to the title page. POWER OFF: To turn the Master Component off, depress the ON/OFF/RESET button for 3 seconds and then release it.

D. Hand Controllers

The Master Component is equipped with two Hand Controllers (each Hand Controller may be unplugged where the coiled cord meets the Master Component.) There are 12 keys on the keypad. These are used for feeding data into the Master Component.

With each cartridge, there are 2 overlays which fit over the keypads on the 2 Hand Controllers. These overlays are keyed to the particular game being played and determine how the keys on the keypad relate to the cartridge. Slip the overlay under the keypad frame.

There are 2 action buttons on both sides of the Hand Controllers. The upper buttons, one on each side, perform the same function for the convenience of either right- or left-handed players. The lower buttons perform varying functions. The functions of all the buttons depend on the cartridge being used and are different for each cartridge overlay.

The disc at the base of the Hand Controller is a directional control for those cartridges in which direction is a factor. There are 16 directional positions on the disc. The direction of the disc corresponds to direction of the television screen. UP on the disc (toward the

keypad) is UP on the screen, etc. For further instructions, refer to the individual game cartridges.

To operate the directional disc, depress the outer edge of the disc with one finger and rotate it around the edge to change the direction on the object you are moving. You have the ability to move the object in any desired direction.

The keypad buttons and directional disc cannot be operated simultaneously. However, the action buttons and directional disc may be operated simultaneously.

When returning the Hand Controller to the Master Component, coil the cable beneath it in the cradle. To avoid permanently overstretching the coiled cables, they should not be pulled out to their extreme length.

E. Intermission and Time Out

1. If, for any reason, you wish to interrupt your game, you may use the Intermission Code. Removing the game overlay and pressing 1 and 9 simultaneously on either Hand Controller will cause the television screen to go blank and game play to stop. To resume game play, simply depress any key on either Hand Controller.
2. If NO functions on either Hand Controller are activated for approximately 5 minutes, the television screen WILL AUTOMATICALLY GO BLANK and the game play will stop. To resume game play, simply depress any key on either Hand Controller. The purpose of this unique feature is to eliminate the possibility of a permanent playfield image being imprinted on the television screen.

NOTICE TO PROJECTION TV OWNERS:

Operating the Master Component for extended periods of time on a projection TV system may cause the stationary game objects to become permanently imprinted on the projection TV picture tube(s). This is especially true when the brightness and contrast controls are set extremely high for game viewing. Please observe the following precautions to minimize the chances of a game image being imprinted on the screen:

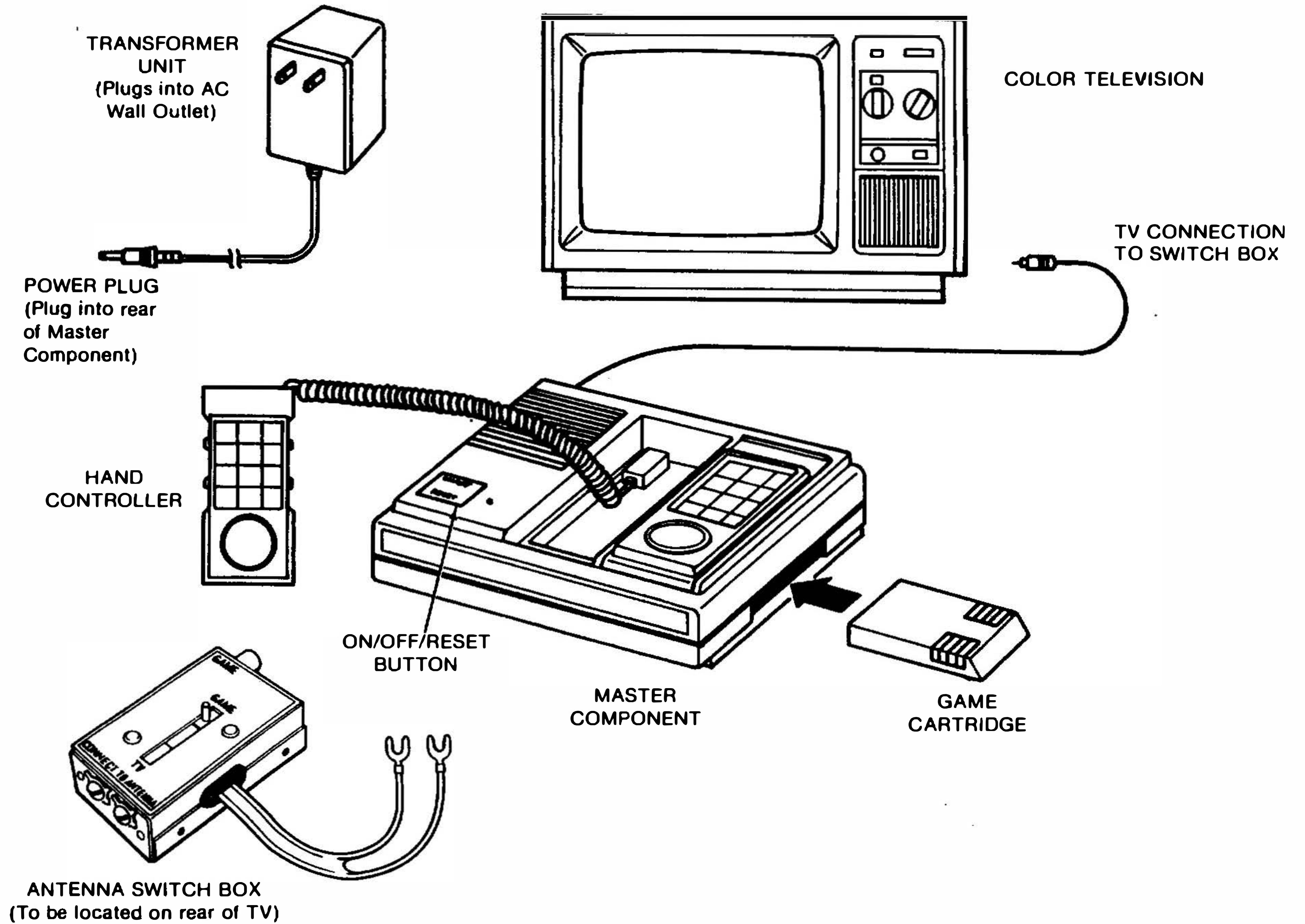

Figure 3 — MATTEL INTELLIVISION MASTER COMPONENT (Wiring Diagram)

1. Always use lowest possible brightness and contrast control settings during game operation.
2. Games containing stationary white or light colored objects should not be played for extended periods of time.
3. Follow your projection TV owner's manual for proper viewing conditions for programming.

SYSTEM DESCRIPTION AND OPERATION

The Intellivision II system consists of a Master Component with two detachable hand controllers, an antenna switch box, RF connecting cable and a wall-mounted transformer unit. The Master Component operates in conjunction with a color television set and an Intellivision game cartridge. Peripheral equipment (such as the Intellivoice™ Voice Synthesis unit) may also be used with the Intellivision II system.

The Master Component system is based on two processors. One is a 16 bit microprocessor (CPU) that computes the game action against the stored program rules. The second is the Standard Television Interface Circuit (STIC) that interprets a condensed memory area and uses this to generate a color video signal. The video signal is applied to the RF modulator to provide the television signal. The user's color television receiver is used for the video display.

User interaction with the game programming is accomplished by the inputting of numerical control and directional information through the hand controllers.

The audio is accomplished by using a programmable sound generator (PSG) integrated circuit (IC) which generates the audio signal to drive the RF modulator. The user's television receiver is used for the audio output.

CONSOLE ASSEMBLY. The Console Assembly contains all electrical circuitry necessary for recall and processing of the program data stored in the game cartridge. Integral with the Console Assembly are the ON/OFF/RESET

switch, power supply board assembly, logic board assembly, and two hand controller assemblies. Recessed compartments at the top of the console are provided for storage of the hand controllers and cables. A slot in the right-hand side of the Console Assembly is the insertion port for the game cartridge. The ON/OFF/RESET switch is located at the lower left-hand corner of the Console Assembly.

A. ON/OFF/RESET SWITCH. This switch has three main functions: When the Master Component is off, depressing this switch will apply power to the unit. When the Master Component is on, quickly tapping this switch will reset the game in play. Finally, when the Master Component is on, holding this switch down for about 3 seconds and then releasing it will turn power to the unit off.

B. POWER SUPPLY BOARD ASSEMBLY. The Power Supply Board converts the AC voltage from the wall-mounted transformer unit into the various DC voltages necessary to operate the Master Component. Additional circuitry on the Power Supply Board senses the activation of the ON/OFF/RESET switch and causes the Master Component to turn on or off. Electrical connection to the Logic Board is via a 10-pin connector.

The Power Supply Board utilizes a switching regulator design to accurately and continuously sense the current being drawn by the Master Component. In this design, the incoming voltage is rectified and then converted into a square wave. The switching

regulator senses the current drain and varies the duty cycle (on time of the square wave compared to the total period) of the square wave. This assures a constant voltage during varying levels of power consumption.

C. LOGIC BOARD ASSEMBLY. The Logic Board Assembly consists essentially of 12 integrated circuits and their associated components, a channel select switch, and an RF modulator, all of which are mounted on the same printed circuit board. A 44-pin connector is provided for game cartridge connection. Two 9-pin connectors are provided for connection of the Hand Controllers. The Logic Board processes program data from the game cartridge and also converts the processed data to an RF signal for color television operation.

D. HAND CONTROLLER ASSEMBLIES. The Hand Controller Assemblies each consist of a printed circuit matrix, a numerical keypad, two pairs of side-mounted pushbuttons, and a 16-position directional control disc. The Hand Controllers provide a means of calling up program information from the game cartridge for processing by the Central Processing Unit (CPU).

ANTENNA SWITCH BOX AND CABLE. The antenna switch box provides the interface between the console assembly and television set. Two spade lugs on the switch box are provided for connection to the television set. Two screws on the switch box are provided for connection to the antenna. The antenna switch box serves to select either the console assembly or the external antenna as the source of RF input to the television set. For the 75 ohm impedance antenna systems, a balun transformer is required.

TRANSFORMER UNIT. The wall-mounted transformer unit converts 120 Volts AC household current to 16 Volts AC. The transformer unit connects to the console assembly through a 2-wire cable, which may be unplugged from the console for easy storage.

THEORY OF OPERATION. Referring to Figure 4, System Block Diagram, the system is based on the use of two processors which time-share a bidirectional bus. The Central Processing Unit (CPU) algorithmically computes the game action against program material stored in the

ROM game cartridge. The Standard Television Interface Chip (STIC) interprets a condensed memory area and uses the information to generate the television display.

The STIC also fetches moving and background picture information from the graphics memory and presents the data as video output. This is done by dividing the television screen into an X-Y coordinate system. For example, the STIC fetches a pattern or game figure from graphics memory to be used in gameplay. The CPU tells the STIC where to position it on the television screen.

CENTRAL PROCESSING UNIT (CPU). The CPU is a complete, 16 bit, single chip, high speed metal oxide semiconductor, large scale integrated circuit (MOS-LSI) microprocessor. It utilizes a 16-bit bidirectional bus to transfer data, addresses and instructions between the microprocessor, memory, and peripheral devices. Two phase timing and synchronization signals are applied to the CPU by the STIC. The CPU bus control outputs serve to define the status of bus operations.

STANDARD TELEVISION INTERFACE CHIP (STIC). The STIC operates within the system by time-sharing a 14-bit bidirectional bus. The STIC's main function is to provide eight coordinate-positioned "foreground" objects. The second function provides a background display facility. The "background" mode utilizes a dedicated area of external memory to store character control codes for each display position. Both modes utilize external memory for the storage of character patterns. The STIC accepts data, address and graphics information from a common multiplexed bus. Demultiplexing and system synchronization are accomplished through three sets of control signals. Note that the data bus is always duplex or bidirectional.

The main synchronization (which operates at television frame rate) synchronizes the CPU algorithms to the intended display sequences, obtains the "background" character descriptors from the external memory and serves to enable the external devices via the 14-bit bus when in the CPU-controlled mode. The second set of control signals is used to specify address, read and write of the external memory where graphic character patterns are stored. When

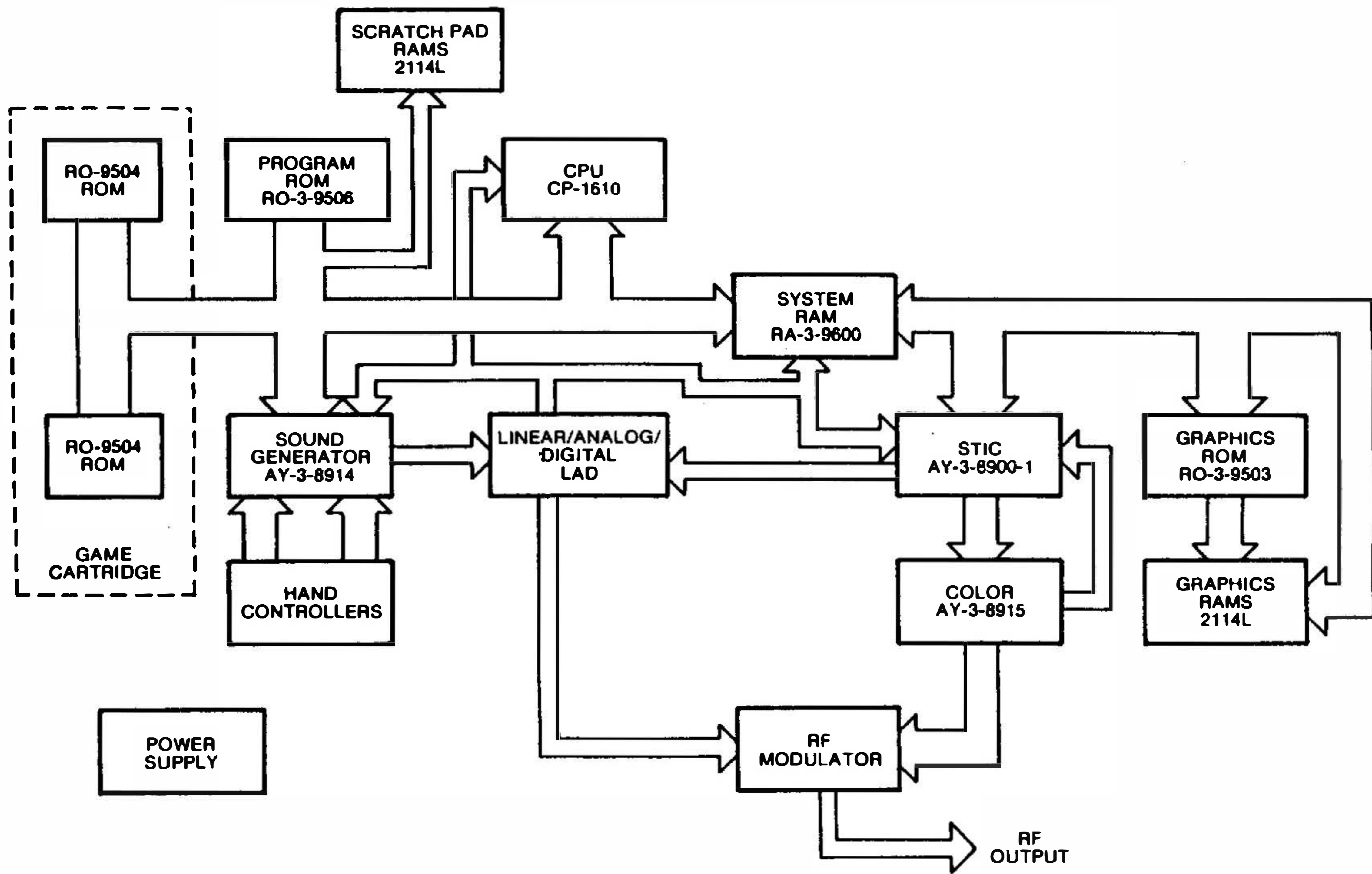

-7-

Figure 4 — BLOCK DIAGRAM

in the CPU-controlled mode, the graphics control bus links the graphics memory to the CPU main memory. The third set of controls is used to specify address, read and write sequences to/from the STIC when the system is in the CPU-controlled mode. Video output codes from the STIC are applied to the color oscillator/master clock generator for processing.

GRAPHICS MEMORY. The graphics memory consists of a graphics read only memory (ROM) and two graphics random access memories (RAMs). The two graphics RAMs are connected to the graphics ROM by an 8-bit static address bus. Address and read instructions are applied to the graphics ROM by the STIC. Output from the graphics memory is applied to the 14-bit secondary data bus.

COLOR OSCILLATOR/MASTER CLOCK GENERATOR. The color oscillator/master clock generator decodes the video output from the STIC and generates a clock signal for system control. Oscillator frequency input is obtained from a 7.159090 MHz crystal and its associated trimmer capacitor. The clock generator provides a 3.579545 MHz clock signal output. Video information from the STIC is applied to five inputs to produce composite sync, color burst, line blanking, screen blanking and video output. The analog outputs of the color oscillator are combined by four external precision resistors to provide a composite video signal to the RF Modulator.

SYSTEM RANDOM ACCESS MEMORY (SYSTEM RAM). The System RAM is a dual port interface, 16-bit wide storage area which serves as the control decoder for CPU control data. The System RAM receives data from the CPU via a 16-bit bidirectional time-multiplexed bus. The direction of data travel is from the CPU to the graphics memory except during a bus reversal condition. This condition is indicated when the CPU requests a read from a graphics address on the 14-bit graphics bus. A 3-bit control bus from the CPU provides strobe signals to the System RAM for the on-chip address latch and main memory area.

PROGRAM READ ONLY MEMORY (PROGRAM ROM). The internal program area is comprised of an executive or system ROM and a scratch pad memory. The executive

ROM contains system operating data. System program data from the executive ROM is transmitted along a 16-bit bidirectional data bus. The program ROM contains program data common to all external programs. Data from the program ROM is transmitted along a 16-bit bidirectional bus. A scratch pad memory RAM associated with the program ROM is provided for computation of the program ROM data. Interconnection of the program ROM and the scratch pad memory RAM is accomplished through a 14-bit bidirectional data bus.

PROGRAMMABLE SOUND GENERATOR. The programmable sound generator (PSG) is a large scale integrated circuit (LSI) designed to produce a wide variety of sounds. All control signals to the PSG are provided by the CPU. Two 8-bit general purpose I/O ports are provided for user interface via the hand controllers. The PSG output is available from three independently programmed analog outputs. The outputs of the PSG is combined on a single line, amplified and then applied to the RF modulator to produce the audio output at the television set.

SYSTEM TESTING

DIAGNOSTIC TEST ROUTINE. The diagnostic test routine should be performed before disassembly of the Master Component. Full instructions covering the operation and analysis of results are included with the Diagnostic Test Cartridge.

CUSTOMER'S GAME CARTRIDGE TEST. Test the customer's Game Cartridge as follows:

- a. Verify that Master Component is connected to television set as outlined in the Operating Instructions.
- b. Set the Antenna Switch Box to GAME. Insert customer's Game Cartridge in

Master Component and depress the reset switch. Check for mistakes in lettering on title picture, jumbled playfield or unwanted characters.

- c. If any problems occur, remove customer's Game Cartridge and check Master Component with a known-good Game Cartridge.
- d. With the known-good Game Cartridge inserted, if problems are not observed, then the customer's Game Cartridge is defective. If problems are still observed, troubleshoot the Master Component.

DISASSEMBLY PROCEDURE

Before disassembly of the Master Component, follow the steps in the Testing Procedure section to determine the most likely cause of the malfunction. Additionally, check the wall-mounted AC adaptor prior to disassembly for the possibility of its malfunctioning. Refer to the Troubleshooting Procedure section for instructions on testing the wall-mounted AC adaptor. Disassemble the Master Component only to the extent necessary to accomplish repairs.

WARNING

MAKE SURE THE MASTER COMPONENT IS UNPLUGGED FROM THE AC ADAPTOR BEFORE DISASSEMBLY. REMOVE ANY GAME CARTRIDGE FROM THE UNIT, DISCONNECT THE RF CABLE FROM THE RF OUTPUT JACK AND THE HAND CONTROLLERS FROM THEIR SOCKETS.

DISASSEMBLY OF CONSOLE ASSEMBLY. Disassemble the Master Component in a clean, well-illuminated area. Refer to Exploded Diagram (Figure 5, Page 22).

Turn console assembly upside down on a surface protected by a soft cloth or a piece of carpet.

- a. Remove two Phillips-head screws securing the top housing assembly to the bottom housing assembly.
- b. Turn console assembly right side up. Gently pull the front of the top housing assembly up and away from the bottom housing assembly. Small catches in the rear of the console assembly prevent the top and bottom housing assemblies from being pulled directly apart.
- c. Remove the 3 Phillips-head screws holding the Power Supply Board to the standoffs on the Logic Board.
- d. Gently lift the Power Supply Board straight up from the Logic Board.
- e. Remove 4 Phillips-head screws holding the Logic Board to the lower housing assembly.
- f. Grasp the Logic Board at the 44-pin game connector and gently pull it straight up and away from the lower housing assembly. Be sure to allow the Channel Select switch to clear its opening in the lower housing assembly.

PRELIMINARY CHECKLIST

Before you refer to the TROUBLESHOOTING Section which follows, look at this list of possible quick solutions. Then, if any problem persists, you should be able to find it in TROUBLESHOOTING.

Press ON/RESET button. With the Test Cartridge inserted, go through the DIAGNOSTIC ROUTINE and check for these problems:

PROBLEM	POSSIBLE SOLUTION
SCREEN IS BLANK	— Press any key on either Hand Controller key pad to recover picture.
NO TV PROGRAMS	— Check connection of cable from Antenna Switch Box to antenna connector on TV. — Make sure Antenna Switch Box is set at TV. — Make sure that coax cable is attached.
BUZZING OR DISTORTED SOUND	— Adjust TV fine tuning controls. — If there is broadcast interference from a strong signal, disconnect antenna coax from Antenna Switch Box. (This must be reconnected for broadcast viewing.)
NO GAME SOUND EFFECTS	— Turn up TV volume control. — Adjust fine tuning.
WHITE-GRAY SCREEN OR SCREEN IS ONE COLOR	— Make sure cartridge is properly inserted.
SNOWY SCREEN (NO RF CARRIER)	— Make sure: — TV tuner is set on the proper channel. — Antenna Switch Box is set at GAME. — Game coax cable is properly plugged into Antenna Switch Box. — Power switch is ON. — Check all connections, including power plug.
TEST IMAGE NOT DISTINCT, AS IF FROM WEAK SIGNAL	— Adjust fine tuning, brightness, and contrast controls. — Check connections at Antenna Switch Box, TV antenna connector, and game output connector.
TEST IMAGE BLURRED, WOBBLY, OR NO COLOR	— Adjust fine tuning, brightness, contrast, and color. — If there is broadcast interference from a strong signal, disconnect antenna cable from Antenna Switch Box. (This must be reconnected for broadcast viewing.)

TROUBLESHOOTING

From a design aspect, the Intellivision II Master Component is a complex configuration of electronic hardware. However, from a repair aspect, the Master Component may be divided into small building blocks, each part modifying or adding to the signals in its own special way. Whenever possible, the repair of the Master Component is simplified by looking at symptoms that occur when a component fails.

It is recommended that the first few time you, the repair technician, troubleshoot a defective Master Component, start at the beginning of this troubleshooting procedure and follow through until the problem is corrected. Familiarity will quickly be gained in identifying the appropriate voltages and waveforms found

at various parts of the circuit. At this time, you will be able to quickly identify the symptoms exhibited by the Master Component and perform the required repair.

When changing Integrated Circuits (ICs):

- **ALWAYS USE A KNOWN-GOOD IC.**
- **ALWAYS FOLLOW PROPER PROCEDURES AND CAUTIONS FOR HANDLING MOS DEVICES.**
- **BE SURE OF CORRECT IC ORIENTATION AND PIN INSERTION.**
- **CHANGE ONLY ONE IC AT A TIME AND LEAVE IN THE KNOWN-GOOD IC UNTIL THE FAULTY ONE IS FOUND.**

TROUBLESHOOTING PROCEDURE:

Run the Diagnostic Test Routine. If a fault is discovered, then the FAILURE display will indicate the ICs most likely to have failed. Replace these ICs. If this does not solve the problem, or if you are unable to run the Diagnostic Test Routine, follow this Troubleshooting Guide.

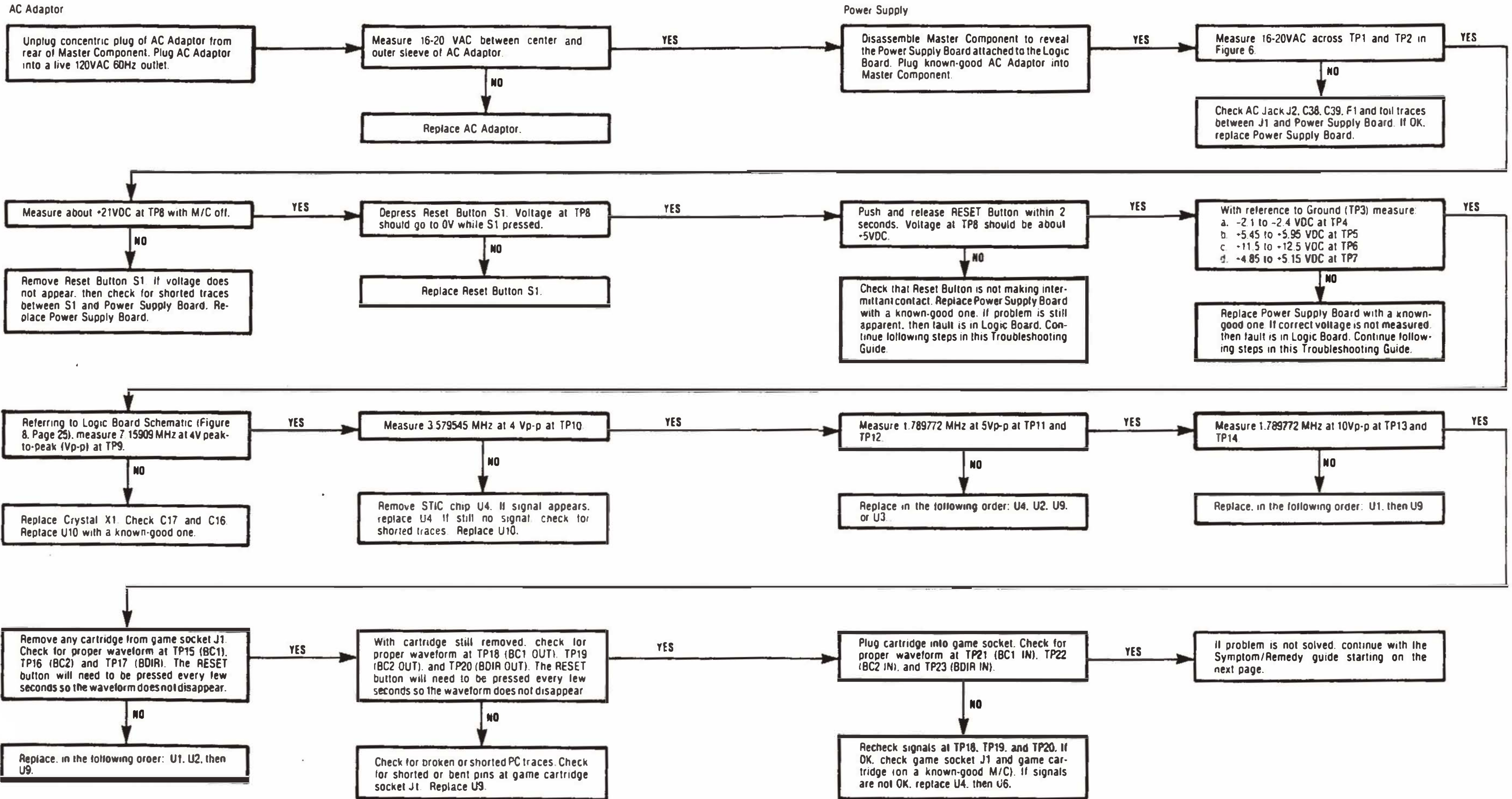

If the problem is not found and corrected with the procedures on the previous page, then follow this Symptom/Remedy Guide:

SYMPTOM	SUSPECT	REMEDY
Snow on TV (with or without diagnostic test pattern visible.)	Unit is not turning on.	Review voltage check in Troubleshooting Guide.
	Fuse is blown.	Check continuity of fuse on Logic Board. Replace if open. If new fuse blows quickly, check for proper voltages from Power Supply Board. If voltages OK, check for shorted components or traces on Logic Board.
	Voltage at pin 2 of RF Modulator is not about +6 VDC.	Check R7 and C18.
	RF Modulator is defective.	Connect a known-good Modulator in parallel with the Modulator. Connect the RF Cable to the known-good Modulator and touch the cases together. If this clears the problem, replace Modulator.
	Solder bridges or foreign material are causing shorts.	Inspect for solder bridges or foreign material on the Logic Board.
	The +12 VDC supply is defective.	Troubleshoot the +12 VDC supply and distribution on the Logic Board.
Grey-white screen with NO flash observed on the TV screen when the reset switch is depressed.	Clock circuitry not functioning.	Review procedure in Troubleshooting Guide on troubleshooting clock circuitry.
	5.7 VDC to STIC missing.	Measure 5.7 VDC at pin 20 of STIC (U4). If not, troubleshoot 5.7 VDC distribution system on Logic Board.
	-2.25 VDC to STIC missing.	Measure -2.5 VDC at pin 40 of STIC (U4). If not, troubleshoot -2.25 VDC distribution system on Logic Board.
	Solder bridges or foreign material causing shorts on Logic Board.	Remove any foreign material or solder bridges.
Grey-white screen WITH flash occurring on the TV screen when reset switch is depressed.	The test cartridge is incorrectly or incompletely inserted into the Master Component.	Insert cartridge correctly.
	Master Component cartridge socket is defective.	Visually inspect socket for bent pins, foreign material, etc.
	Defective Test Cartridge.	Try another cartridge.
	Clock signal path not complete.	Review procedure in Troubleshooting Guide on checking clock circuitry.
	+5 VDC supply problems.	Troubleshoot +5 VDC supply and distribution path.
	Defective IC.	Insert test cartridge and run Diagnostic Test Routine. Replace any ICs that are indicated as failed.

SYMPTOM	SUSPECT	REMEDY
<p>Grey-white screen WITH flash occurring on the TV screen when reset switch is depressed. (continued)</p>	<p>Defective IC (continued).</p>	<p>If Test Routine will not run (using a known-good test cartridge) and all voltages are OK, replace the ICs in the following order: U1, U2, U4, U3, or U6.</p>
	<p>Incorrect or missing bus control signals.</p>	<p>Review procedure in Troubleshooting Guide on checking bus control signals.</p>
	<p>Solder bridges or foreign material causing shorts.</p>	<p>Remove any foreign material or solder shorts.</p>
<p>Incorrect, extra, or missing video patterns or characters.</p>	<p>One or more ICs are defective.</p>	<p>Insert test cartridge and Diagnostic Test Routine. Replace any indicated defective ICs. Most graphics problems are caused by U2, U4, U5, U7, or U8.</p>
	<p>Incorrect or missing DC Voltages.</p>	<p>Check for correct DC voltages on each IC (refer to Schematic, Figure 8).</p>
	<p>Test cartridge is defective.</p>	<p>Try a known-good Test Cartridge.</p>
	<p>Solder bridges or foreign material is causing shorts.</p>	<p>Remove any foreign material or solder shorts.</p>
<p>Distorted TV picture.</p>	<p>Interference from a nearby television or radio transmitter.</p>	<p>Switch television and Master Component to another channel and/or disconnect the antenna wire from the antenna switch box.</p>
	<p>The test setup is incorrect.</p>	<p>Check all television controls and connections for agreement between the TV VHF channel selector and the Master Component channel selector.</p>
	<p>STIC IC (U4) or Color IC (U10) is defective.</p>	<p>Replace these ICs (one at a time) with known-good ones.</p>
	<p>Defective RF modulator.</p>	<p>Connect a known-good modulator in parallel with the modulator. Connect the RF cable to the known-good modulator and touch the two modulator cases together. If the problem clears, replace the modulator.</p>
	<p>Solder bridges or foreign material causing shorts.</p>	<p>Remove any foreign material or solder bridges.</p>
<p>No sound (picture and video OK).</p>	<p>TV volume turned down.</p>	<p>Check TV Volume setting.</p>

SYMPTOM	SUSPECT	REMEDY
No sound (picture and video OK). (continued)	Sound IC (U6), U3, or U9 is defective.	Scope for audio signal at pin 4 of U6 during Audio Test on Test Cartridge. If no Audio, replace U6, U9, then U3. If signal at pin 4 of U6 OK, but no signal at pin 9 of U9, replace U9.
	RF Modulator is defective.	First check the audio input lead of the modulator for signal. If signal is present, connect a known-good modulator in parallel with the modulator. Connect the RF cable to the known-good modulator and touch the two modulator cases together. Run the Sound Test on the Test Cartridge. If sound is OK, replace the modulator.
	Solder bridges or foreign material causing shorts.	Remove solder bridges or foreign material.
Hand Controller malfunctions.	The Hand Controller is defective.	Plug in a known-good Hand Controller and perform the Hand Controller Test.
	U6 or U3 is defective.	Replace U6, then U3.
	The 9 pin connector on the Logic Board for the Hand Controllers is defective.	Check the 9 pin connector and associated traces on the Logic Board.
	Other ICs are defective.	Replace, in the following order: U4, U2, U1, U12, and U13.
The picture suddenly goes blank during the diagnostic test.	The test cartridge is defective.	Try another cartridge. Also check the Master Component cartridge slot.
	One or more ICs are defective.	Replace, in the following order: U1, U2, and U4.
	The reset button is defective.	Check the reset button.
	Crystal X1 is defective.	GENTLY tap the crystal and observe the picture.
	Foreign material is causing an intermittent short.	Inspect the Logic Board for foreign material.
Picture action "freeze-up."	One or more ICs are defective.	Replace, in the following order: U1, U4, U2, and U3.
	The Test Cartridge is defective.	Try another cartridge.
	The Master Component cartridge socket is defective.	Inspect the cartridge socket for bent pins, foreign materials, etc.
Channel Select switch does not operate correctly.	The switch is defective.	Replace the switch.
	The modulator is defective.	Connect a known-good modulator in parallel with the modulator. Connect the RF cable to the known-good modulator and touch the two cases together. Switch the Channel Select. If the channel now changes, replace the modulator.

SYMPTOM	SUSPECT	REMEDY
<p>The picture has the wrong colors or no colors.</p>	<p>The TV controls are set wrong.</p>	<p>Check all TV controls.</p>
	<p>The crystal X1 is set to the wrong frequency.</p>	<p>Check the frequency at pin 15 of U10. It should be 3.579545 MHz +/- 100Hz. Adjust the frequency by adjusting variable capacitor (C17).</p>
	<p>STIC (U4) or Color (U10) ICs are defective.</p>	<p>Replace U4, then U10.</p>
	<p>Solder bridges or foreign material causing a short.</p>	<p>Remove any solder bridges or foreign material.</p>

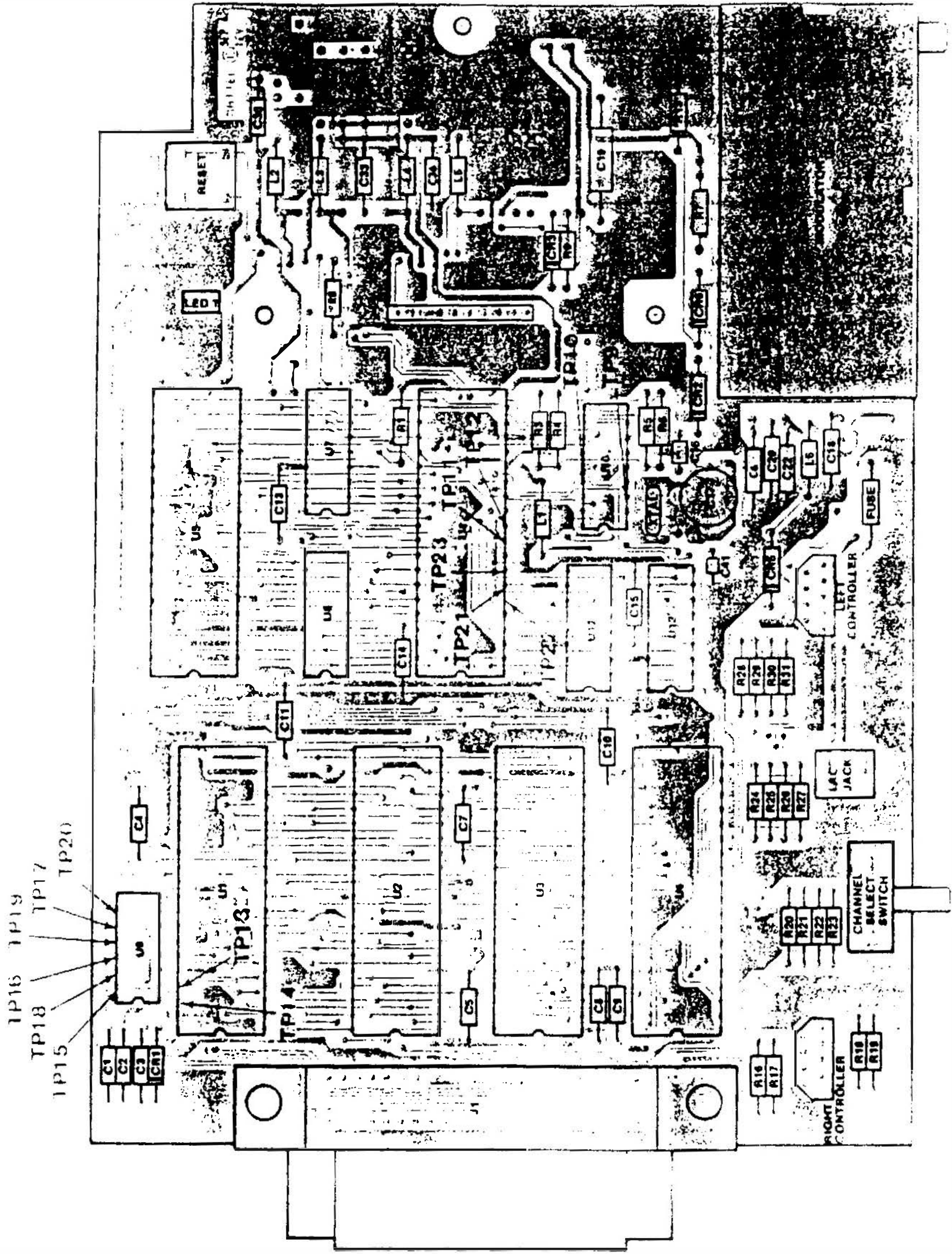

Figure 5 — P.C. BOARD COMPONENT LAYOUT

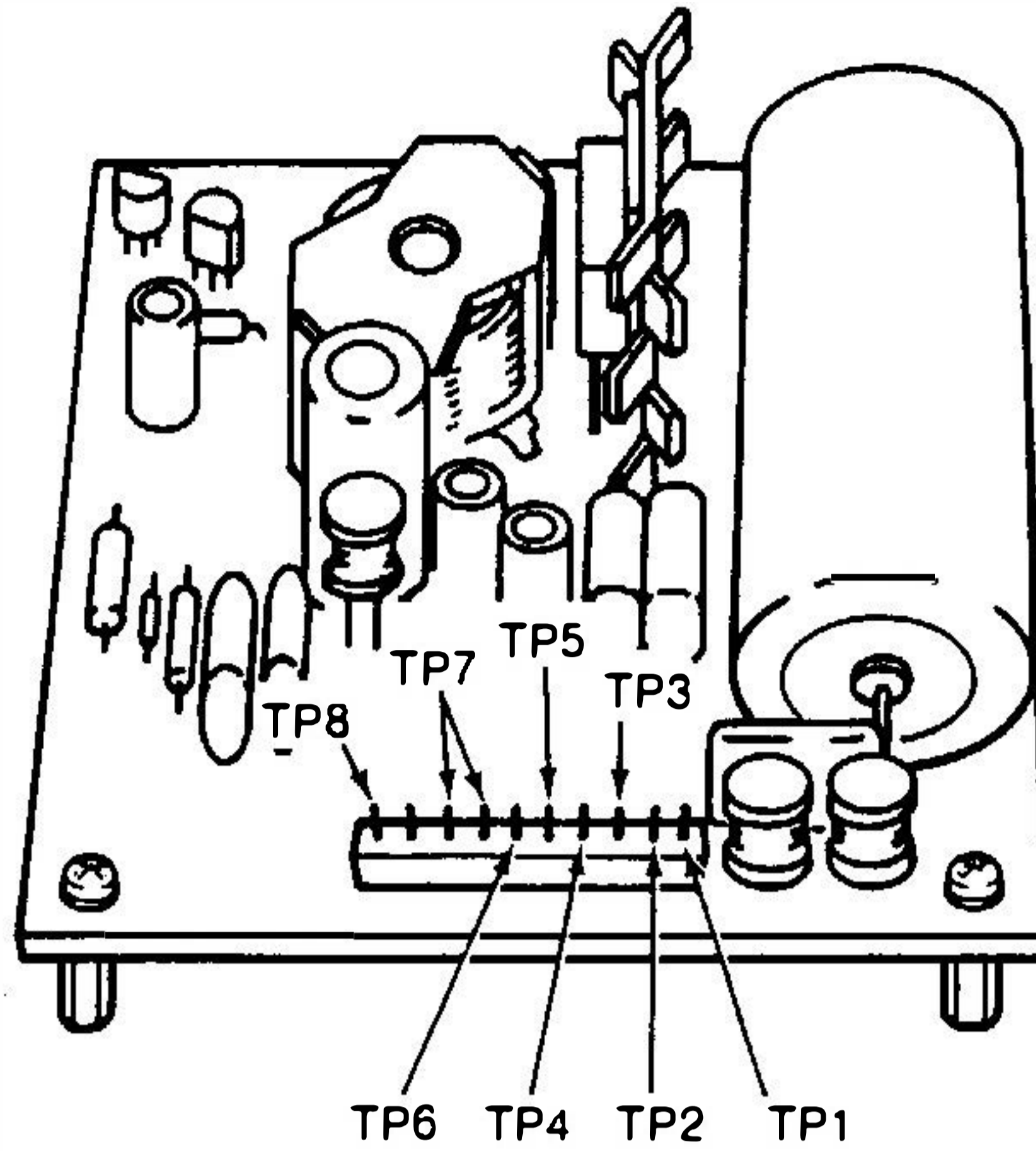

Figure 6 — Power Supply Board

TP1 - TP 2	16-20VAC
TP3	Ground Connection
TP4	-2.10 to -2.40 VDC
TP5	+5.45 to +5.95 VDC
TP6	+11.5 to +12.5 VDC
TP7	+4.85 to +5.15 VDC
TP8 ..	Control (+21VDC/unit Off, +5VDC/unit On, 0VDC/Reset pressed)

ADJUSTMENTS

MASTER CLOCK ADJUSTMENT.

1. Connect a frequency counter with a high input impedance (100K ohms or higher) to pin 15 of U10 and ground.
2. Adjust C17 (variable capacitor) so the frequency counter indicates 3.579545 MHz \pm 100Hz.

RF OUTPUT ADJUSTMENT.

1. Connect a frequency counter with minimum input sensitivity of 2mV RMS at 70MHz to RF Output Jack.
2. Set Channel Select switch to channel 3.
3. Depress and hold RESET Button and adjust video frequency core on RF Modulator so frequency counter reads 61.250MHz \pm 250kHz. Use only a non-ferrous adjustment tool.

CAUTION: Use care not to damage the core.

4. Set Channel Select switch to channel 4. Verify the frequency counter reads 67.65MHz \pm 250kHz.

SOUND BUZZ ADJUSTMENT.

1. Adjust volume on TV set for a normal level. No sync buzz or hash sound should be heard.
2. If a buzz is heard, adjust the sound coil on RF modulator for minimum buzz. Use only a non-ferrous adjustment tool.

CAUTION: Use care not to damage the core.

3. If the buzz cannot be reduced to a satisfactory level, replace the modulator.

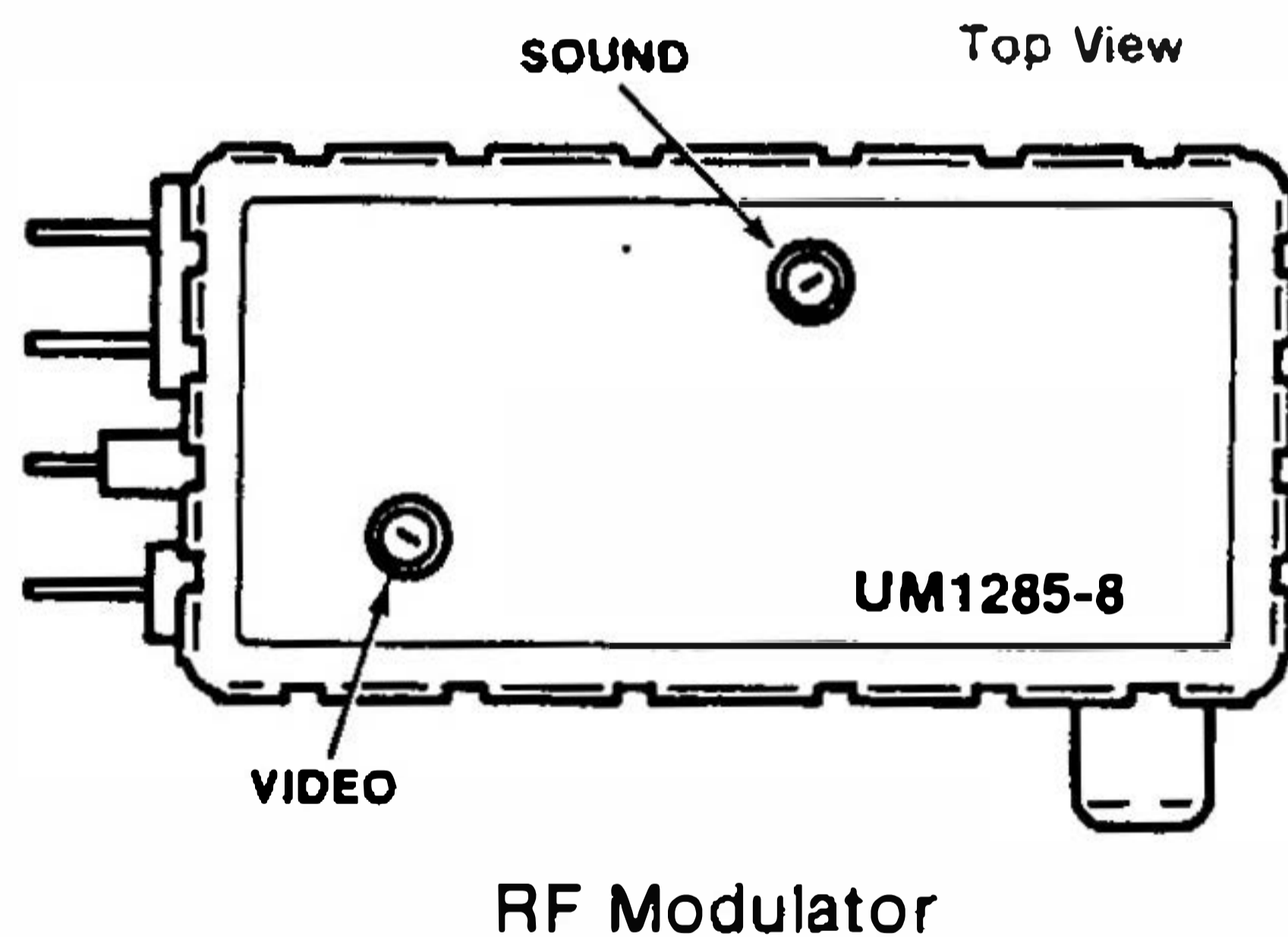

PARTS LIST

REF. DESIGNATION	DESCRIPTION	PART NUMBER
①	Lower Housing	5872-2109
②	Rubber Foot	2609-9489
	Label – FCC & Serial No.	5872-0350
③	Logic Board with parts	N/A
R1, R16-R31	Resistor, 5.6K ohm 5% 1/4W	0095-0961
R3	Resistor, 2.7K ohm 5% 1/4W	0095-0881
R4	Resistor, 5.4K ohm 5% 1/4W	0084-0929
R5	Resistor, 11K ohm 5% 1/4W	0095-0032
R6	Resistor, 22K ohm 5% 1/4W	0095-0102
R7	Resistor, 180 ohm 5% 1/2W	0095-0556
R8	Resistor, 150 ohm 5% 1/4W	0095-0580
R9	Resistor, 10K ohm 5% 1/4W	0095-0022
R13	Resistor, 18K ohm 5% 1/4W	0095-0082
C1-C5, C7-C11, C13-C15, C18, C30, C33, C35, C36	Capacitor, 0.1uF 25V	0085-1510
C16	Capacitor, 20pF 15V NPO	0085-0720
C17	Capacitor, variable 5-50pF	0099-0730
C19	Capacitor, 4.7uF 6.3V Elect.	0085-0031
C20	Capacitor, 220pF 15V	0085-0028
CR1, CR3	Diode, 1N4001	0099-1030
CR2, CR5, CR6	Diode, 1N914	0099-1040
LED1	Light Emitting Diode (LED)	5872-0080
U1	Integrated Circuit, CP1610 (CPU)	0098-0520
U2	Integrated Circuit, RA-3-9600 (SRAM)	0098-0530
U3	Integrated Circuit, RO-3-9506 (PROM)	5872-0020
U4	Integrated Circuit, AY-3-8900-1 (STIC)	0098-0640
U5	Integrated Circuit, RO-3-9503 (GROM)	0098-0570
U6	Integrated Circuit, AY-3-8914 (Sound)	0098-0660
U7, U8, U12, U13	Integrated Circuit, 2114L (RAM)	0098-0710
U9	Integrated Circuit, LAO	5872-0010
U10	Integrated Circuit, AY-3-8915 (Color)	0098-0680

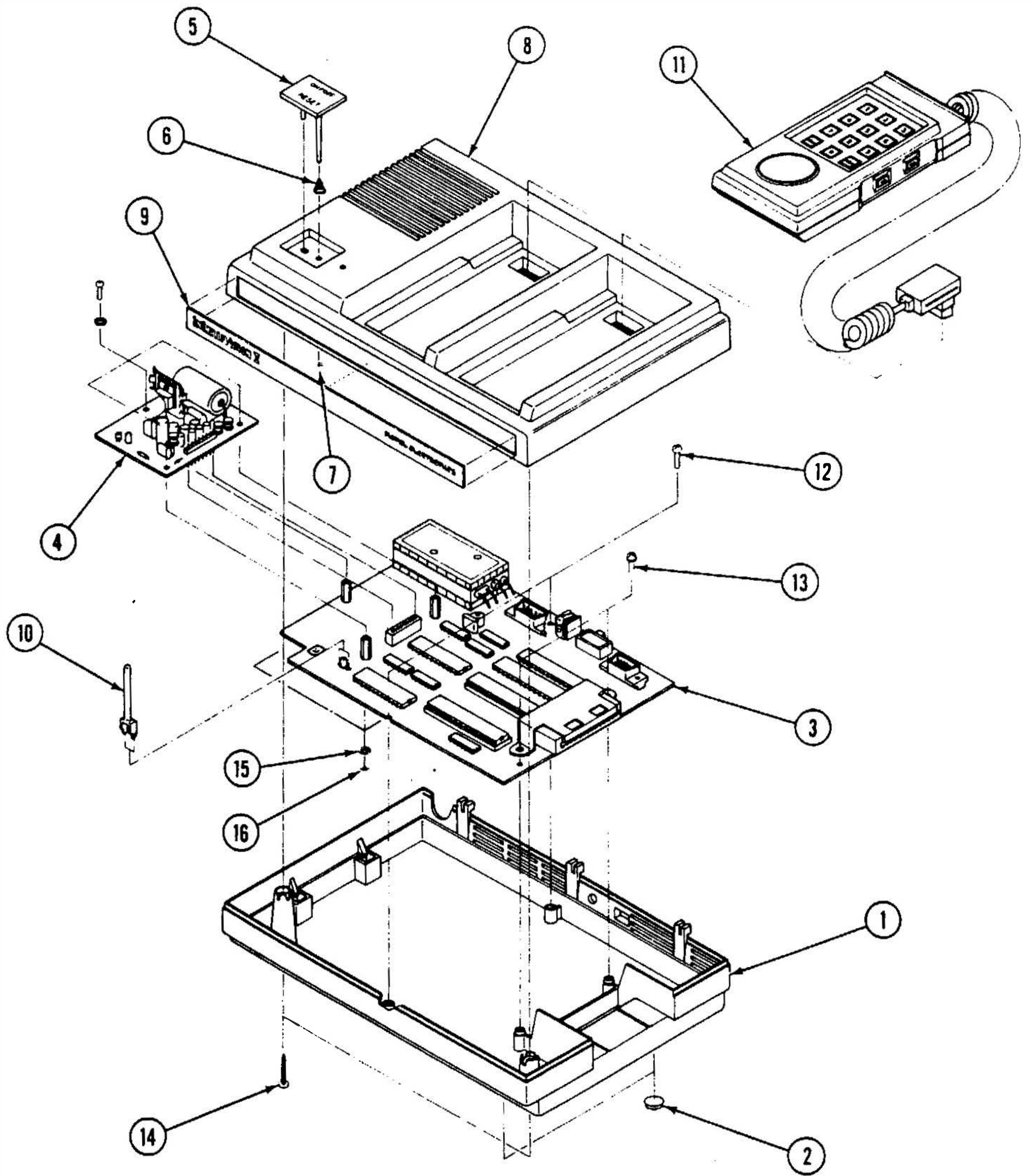
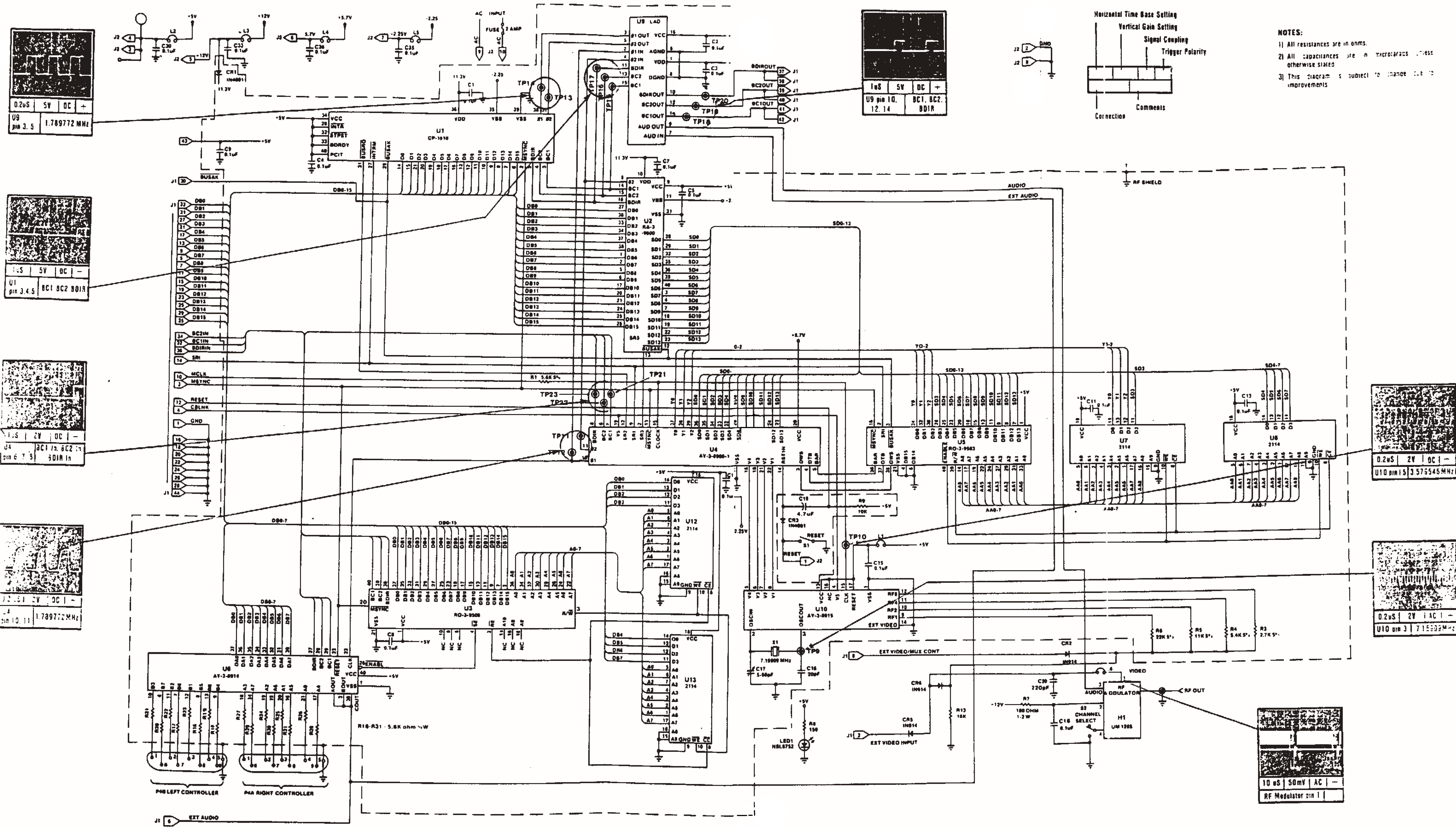

Figure 7 — EXPLODED VIEW OF MASTER COMPONENT

REF. DESIGNATION	DESCRIPTION	PART NUMBER
X1	Crystal, 7.15909MHz +/- 0.003%	0089-0158
H1	RF Modulator	2609-4689
S1	Domed Switch, Reset	0099-1140
S2	Switch, Channel Select	5872-9559
	IC Socket, 40-pin DIP (for U1, U2 and U4)	0099-1510
	Connector, 10-pin (Power supply to Logic Board)	5872-9359
J1	Connector, 44-pin (Game cartridge)	5872-9399
	Adaptor (for J1)	5872-2169
P4A, P48	Connector, 9-pin (Hand controller)	0099-2580
	Jack, AC Power	5872-9099
F1	Fuse, 2.0 Amp	0089-0115
L1-L6	Ferrite Bead	0099-1360
④	Power Supply Board with parts	5872-9539
⑥	ON/OFF/RESET Button	5872-2129
⑥	Spring (RESET Button)	2609-4269
⑦	Pushnut Fastener	0405-0852
⑥	Upper Housing Assembly (upper housing with inlay)	5872-9719
⑨	Inlay (for upper housing)	5872-4519
⑩	Light Pipe (for LED)	5872-2199
⑪	Hand Controller, with all parts	5872-9059
⑫	Screw, 8-18x3/8" (Logic board to lower housing)	0405-0176
⑬	Screw, 8-18x3/8" (Adaptor to lower housing)	0150-0220
⑭	Screw, 8-18x3/4" (Upper to lower housing)	0405-0832
⑮	Lockwasher, 4-40 (Standoff to logic board)	0150-0080
⑮	Nut, 4-40 (Standoff to logic board)	0150-0070
	Switchbox	2609-9609
	RF Cable	2609-9599
	Wall-Mounted Transformer	5872-9629

DISASSEMBLY NOTES:



NOTES:
 1) All resistances are in ohms.
 2) All capacitances are in microfarads unless otherwise stated.
 3) This diagram is subject to change for improvements.

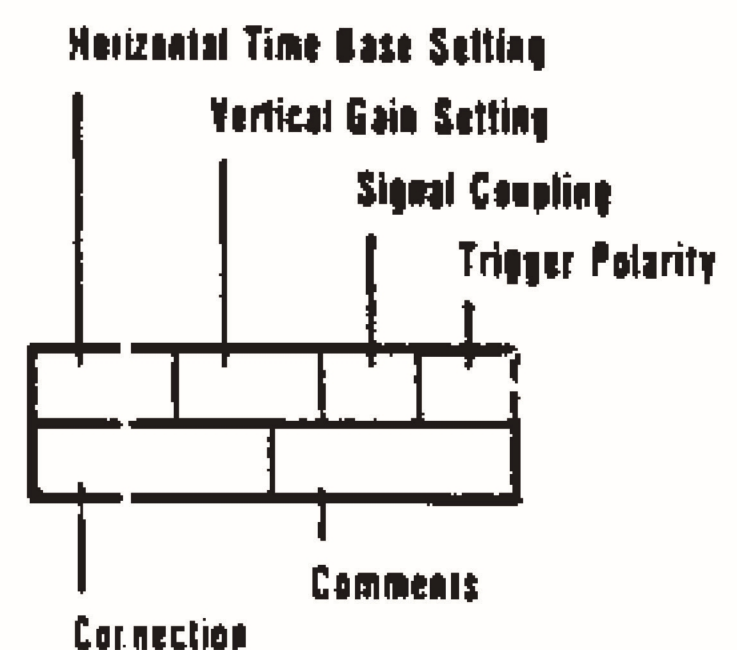

0.2uS 5V DC +
 U9 pin 3, 5 1.789772 MHz

1.5 5V DC -
 U1 pin 3, 4, 5 BC1 BC2 B01A

1.5 2V DC -
 U4 pin 6, 7, 3 BC1 RA, BC2 RA B01A In

1.5 2V DC -
 U10 pin 11 1.789772 MHz

0.2uS 2V DC -
 U10 pin 13 3.575545 MHz

0.2uS 2V AC 1 -
 U10 pin 3 7.155324 MHz

10 uS 50mV AC -
 RF Modulator pin 1

Figure 8 — SCHEMATIC DIAGRAM

INTELLIVISION II

